

Pilot Operated Check Valves

These check valves allow flow in one direction and prevent flow in the reverse direction, until operated by pilot pressure to allow free reverse flow. The specified cracking pressure is required to open the valve to allow free flow direction.

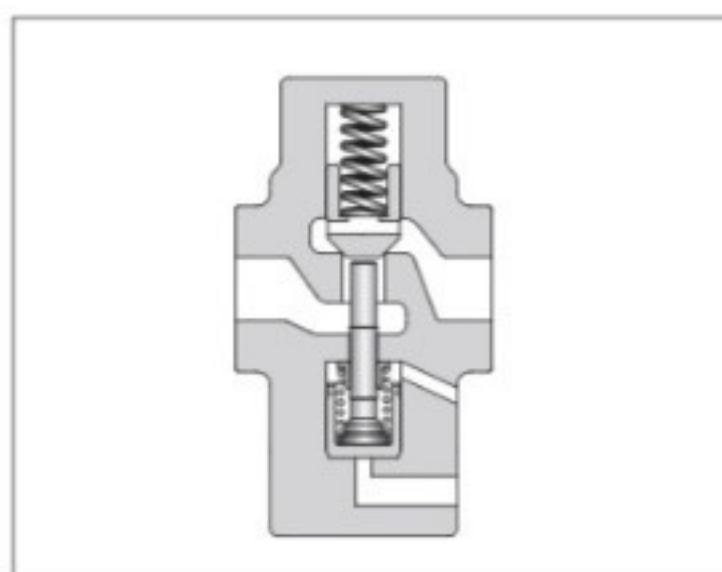

Graphic Symbols

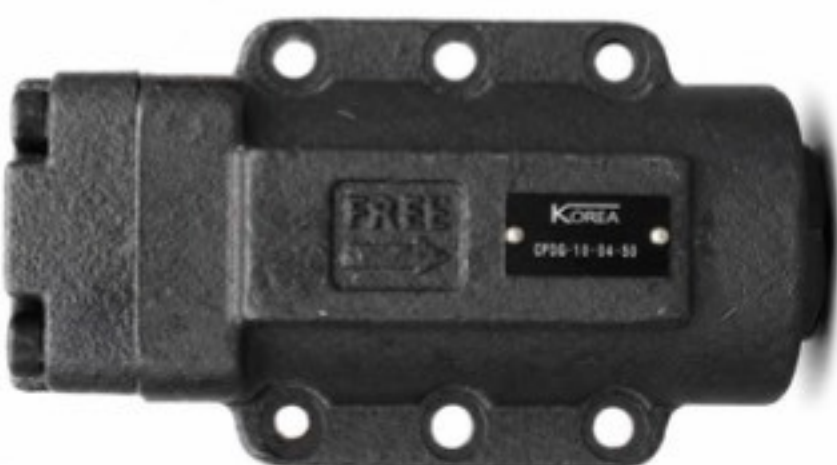

Specifications

Type of Connection	Model Numbers	Rated Flow * L/min (U.S.GPM)	Max. Operating Pres. MPa (PSI)	Cracking Pres. MPa (PSI)	Approx. Mass kg (lbs.)
Threaded Connection	CPT/CPDT-03-*-50*	40 (10.6)	25 (3630)	0.04 (6)	3.0 (6.6)
	CPT/CPDT-06-*-50*	125 (33)		0.2 (29)	5.5 (12.1)
	CPT/CPDT-10-*-50*	250 (66)		0.35 (50)	9.6 (21.2)
Sub-plate Mounting	CPG/CPDG-03-*-50*	40 (10.6)	25 (3630)	0.04 (6)	3.3 (7.3)
	CPG/CPDG-06-*-50*	125 (33)		0.2 (29)	5.4 (11.9)
	CPG/CPDG-10-*-50*	250 (66)		0.35 (50)	8.5 (18.7)

* Rated flow is the approximate flow rate, when there is a free flow pressure drop of maximum 0.3 MPa (44 PSI), the fluid has a specific gravity of 0.85 and a kinematic viscosity of 20 mm²/s (98 SSU), and the cracking pressure is 0.04 MPa (6 PSI).

Model Number Designation

F-	CP	T	03	-E	-04	-50	*
Special Seals	Series Number	Type of Connection	Valve Size	Drain Connection	Cracking Pres. MPa (PSI)	Design Number	Design Standards
F: Special Seals for Phosphate Ester Type Fluids (Omit if not required)	CP: Pilot Operated Check Valve CPD: Decompression Type Pilot Operated Check Valve	T: Threaded Connection	03	None: Internal Drain	04: 0.04 (6) 20: 0.2 (29) 35: 0.35 (50) 50: 0.5 (70)	50	None: Japanese Std. "JIS" 80: European Design Std. 90: N. American Design Std.
			06			50	
			10			50	
		G: Sub-plate Mounting	03	E: External Drain		50	None: Japanese Std. "JIS" & European Design Std. 90: N. American Design Std.
			06			50	
			10			50	

Mounting Bolts

Socket head cap screws in the table below are included.

Valve Model Numbers	Socket Head Cap Screw		Qty.
	Japanese Standard "JIS" & European Design Standard	N.American Design Standard	
CP*G-03	M10 × 45 Lg.	3/8-16 UNC × 1-3/4 Lg.	4
CP*G-06	M10 × 50 Lg.	3/8-16 UNC × 2 Lg.	4
CP*G-10	M10 × 55 Lg.	3/8-16 UNC × 2-1/4 Lg.	6

Yuken can offer flanged connection valves described below.

For details, contact us.

Model Numbers	Rated Flow L/min (U.S.GPM)	Max. Operating Pressure MPa (PSI)
CP*F-10-*-50*	250 (66)	25 (3630)
CP*F-16-*-50*	600 (159)	25 (3630)

Sub-plate

Valve Model Numbers	Japanese Standard "JIS"		European Design Standard		N. American Design Standard		Approx. Mass kg (lbs.)
	Sub-plate Model Numbers	Thread Size	Sub-plate Model Numbers	Thread Size	Sub-plate Model Numbers	Thread Size	
CP*G-03	HGM-03-20	Rc 3/8	HGM-03-2080	3/8 BSP.F	HGM-03-2090	3/8 NPT	1.6 (3.5)
	HGM-03X-20	Rc1/2	HGM-03X-2080	1/2 BSP.F	HGM-03X-2090	1/2 NPT	1.6 (3.5)
CP*G-06	HGM-06-20	Rc 3/4	HGM-06-2080	3/4 BSP.F	HGM-06-2090	3/4 NPT	2.4 (5.3)
	HGM-06X-20	Rc 1	HGM-06X-2080	1 BSP.F	HGM-06X-2090	1 NPT	3.0 (6.6)
CP*G-10	HGM-10-20	Rc 1-1/4	HGM-10-2080	1-1/4 BSP.F	HGM-10-2090	1-1/4 NPT	4.8 (10.6)
	HGM-10X-20	Rc 1-1/2	HGM-10X-2080	1-1/2 BSP.F	HGM-10X-2090	1-1/2 NPT	5.7 (12.6)

• Sub-plates are available, specify the sub-plate model number from the table above. When sub-plates are not used, the mounting surface should have a good machined finish.

• Sub-plates are shared with those for H Type Pressure Control Valves. Refer to pages 244 to 246 for dimensions.

Instructions

Operation of internal and external drain types

When the outlet side P1 is directly connected to the tank in reversed free flow (Fig. a), the internal drain type is normally used. When the back pressure is applied to the outlet side P1 (Fig. b), be sure to use the external drain type.

Minimum pilot pressure characteristics

That depends on the pressure of the inlet side P2 in the reversed free flow.

This value can be determined from the characteristics chart.

Caution on replacement of 20 design low cracking pressure type valves with 50 design valves.

In 20 design valve with cracking pressure of 0.035 MPa (5 PSI) (Code "5"), for closing the valve completely and certainly, it was necessary to introduce the pressurized oil into the drain port to push down the piston compulsory.

While in 50 design valve with cracking pressure of 0.04 MPa (6 PSI) (Code "6"), it has such structure that the valve can be closed completely and certainly without introducing the pressurized oil into the drain port. On the contrary, what is worse is that if the pressurized oil is introduced into the drain port, the oil acts towards the direction of opening the valve, which is very dangerous and has to be absolutely avoided. Therefore, please do not supply any pressurized oil into the drain port in case of using 50 design valve.

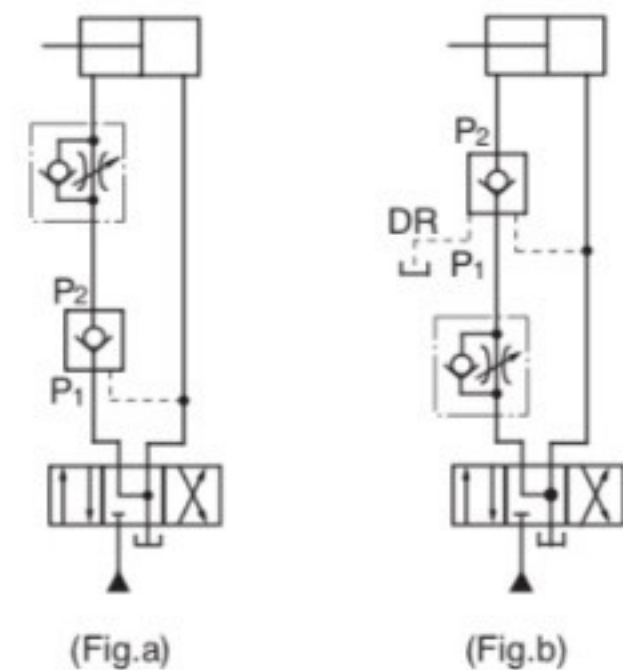

(Fig.a)

(Fig.b)

WARNING

The machinery, if misused due to failure to observe the "Cautions" on the left, may perform unforeseeable movements, resulting in a disastrous accident.

CPT/CPDT-03-**-**-50/5080/5090
 CPT/CPDT-06-**-**-50/5080/5090
 CPT/CPDT-10-**-**-50/5080/5090

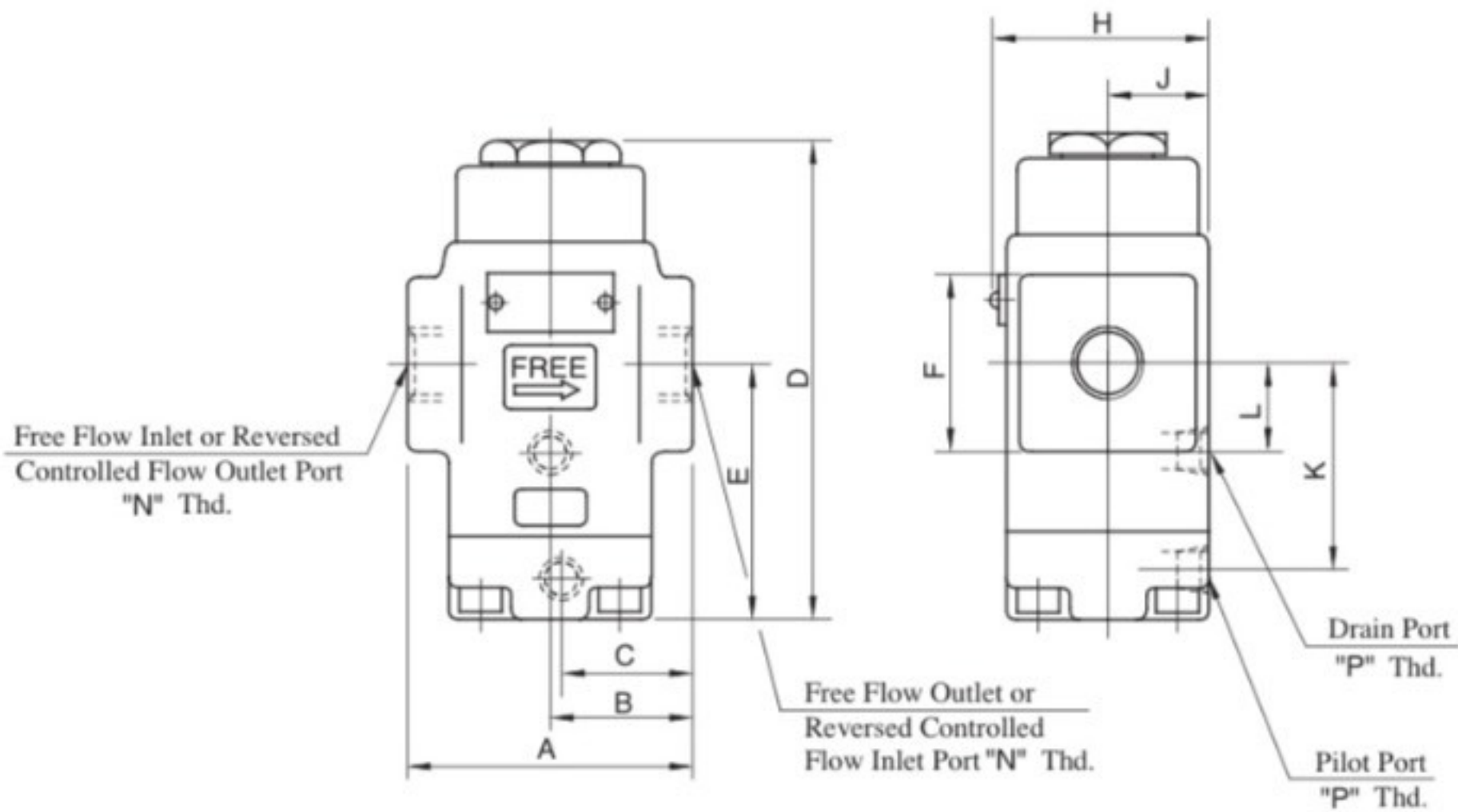

Model Numbers	Dimensions mm (Inches)										Thread Size	
	A	B	C	D	E	F	H	J	K	L	"N" Thd.	"P" Thd.
CPT/CPDT-03-**-**-50	80 (3.15)	40 (1.57)	39 (1.54)	150.5 (5.93)	84.5 (3.33)	38 (1.50) Dia.	60 (2.36)	29 (1.14)	67.5 (2.66)	26.5 (1.04)	Rc 3/8	Rc 1/4
CPT/CPDT-03-**-**-5080											3/8 BSP.F	1/4 BSP.F
CPT/CPDT-03-**-**-5090											3/8 NPT	1/4 NPT
CPT/CPDT-06-**-**-50	96 (3.78)	48 (1.89)	47 (1.85)	171.5 (6.75)	92.5 (3.64)	62 (2.44) SQ.	72 (2.83)	35 (1.38)	75.5 (2.97)	31 (1.22)	Rc 3/4	Rc 1/4
CPT/CPDT-06-**-**-5080											3/4 BSP.F	1/4 BSP.F
CPT/CPDT-06-**-**-5090											3/4 NPT	1/4 NPT
CPT/CPDT-10-**-**-50	140 (5.51)	70 (2.76)	64 (2.52)	203.5 (8.01)	113 (4.45)	80 (3.15) SQ.	82 (3.23)	40 (1.57)	96 (3.78)	43 (1.69)	Rc 1-1/4	Rc 1/4
CPT/CPDT-10-**-**-5080											1-1/4 BSP.F	1/4 BSP.F
CPT/CPDT-10-**-**-5090											1-1/4 NPT	1/4NPT

CPG/CPDG-03-**-50/5090
CPG/CPDG-06-**-50/5090

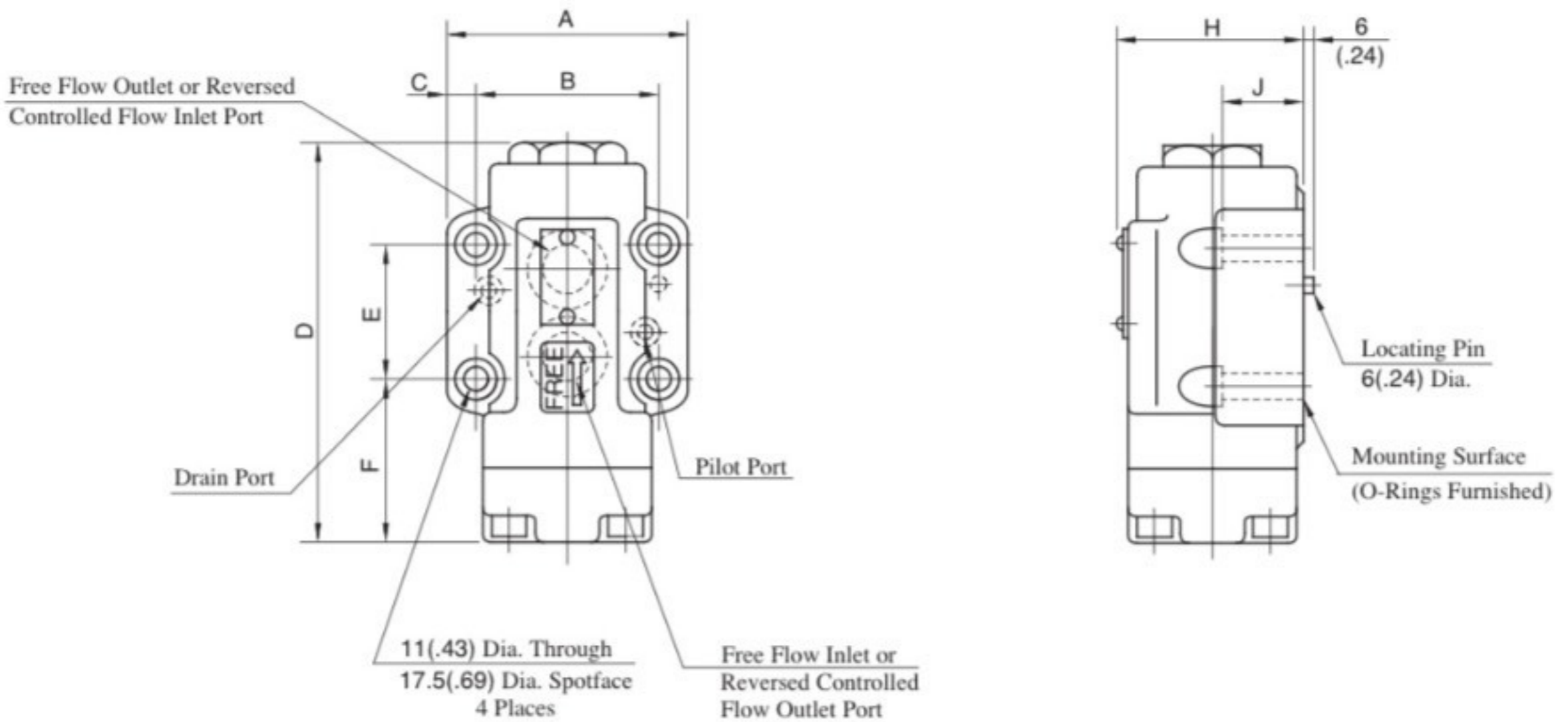

Model Numbers	Dimensions mm (Inches)								Mounting Surface
	A	B	C	D	E	F	H	J	
CPG/CPDG-03-**-50/5090	90 (3.54)	66.7 (2.63)	11.7 (.46)	150.5 (5.93)	42.9 (1.69)	66 (2.60)	62 (2.44)	30 (1.18)	ISO 5781-AG-06-2-A
CPG/CPDG-06-**-50/5090	102 (4.02)	79.4 (3.13)	11.3 (.44)	171.5 (6.75)	60.3 (2.37)	67.5 (2.66)	74 (2.91)	35 (1.38)	ISO 5781-AH-08-2-A

CPG/CPDG-10-**-50/5090

Mounting surface: ISO 5781-AJ-10-2-A

DIMENSIONS IN
MILLIMETRES (INCHES)

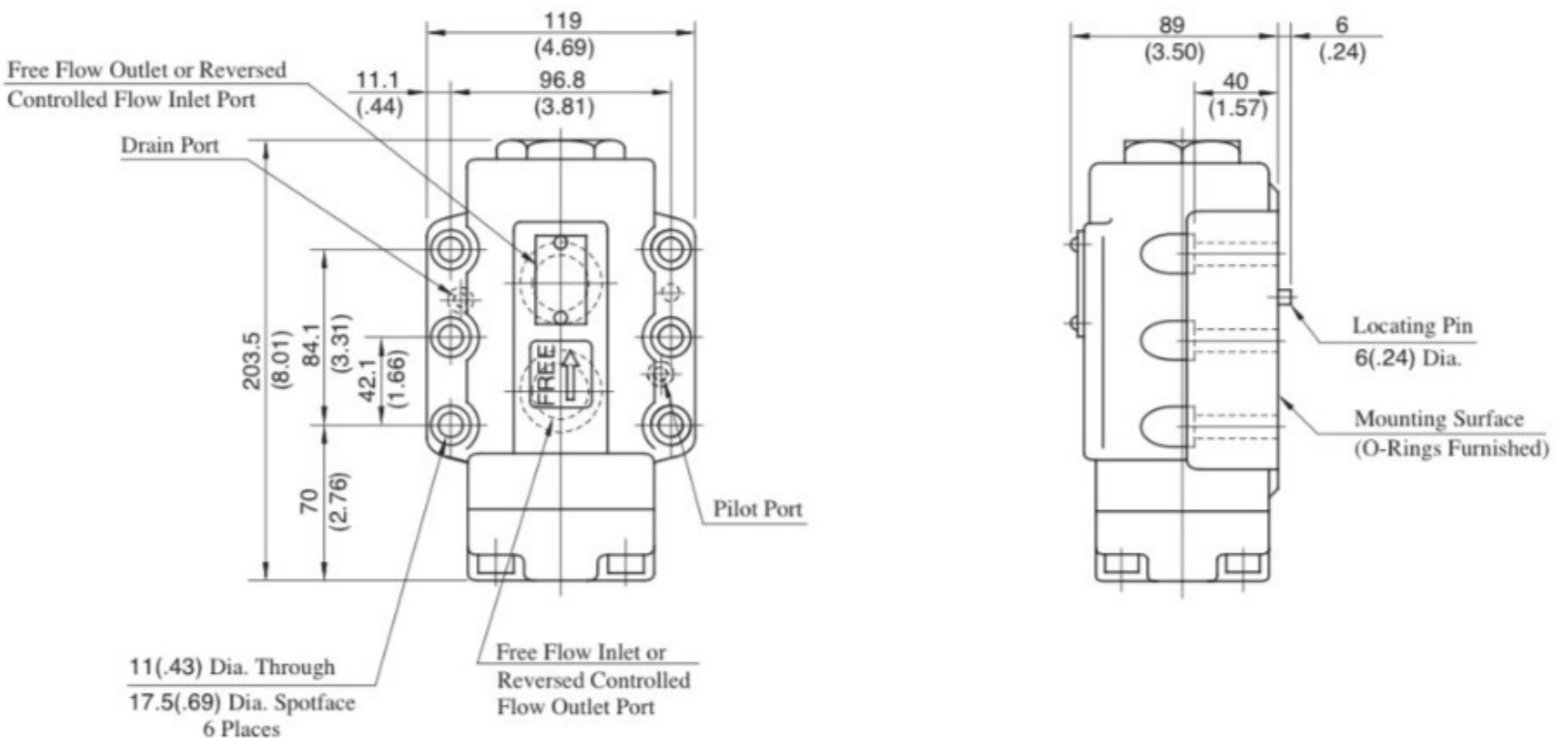

Hydraulic Fluid: Viscosity 30 mm²/s (141 SSU), Specific Gravity 0.850

Pressure Drop

CPT-03, CPDT-03

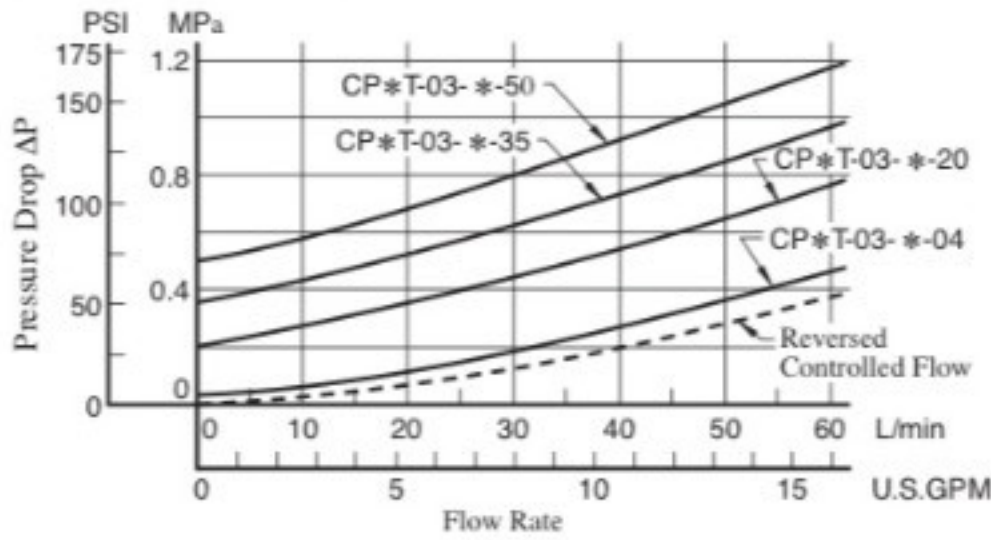

CPG-03, CPDG-03

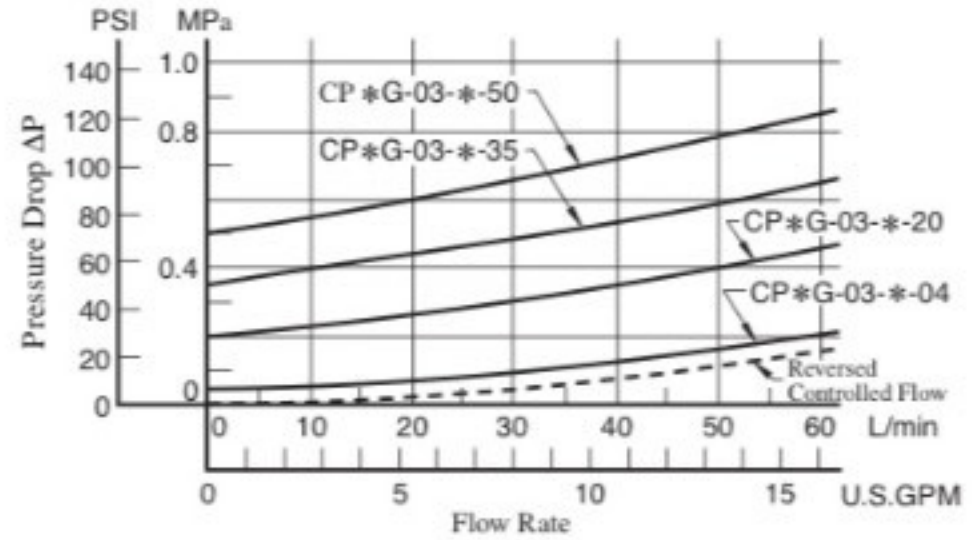

CPT-06, CPDT-06

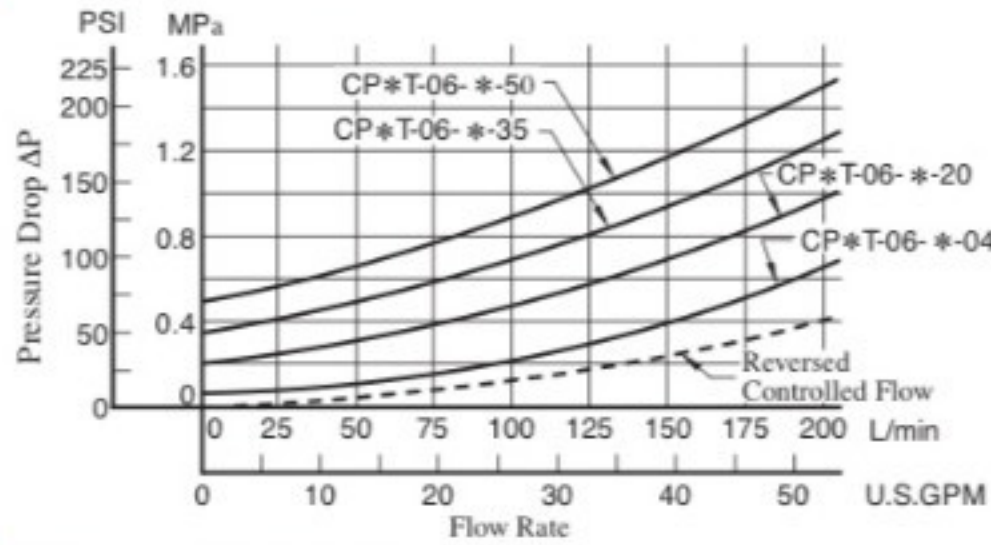

CPG-06, CPDG-06

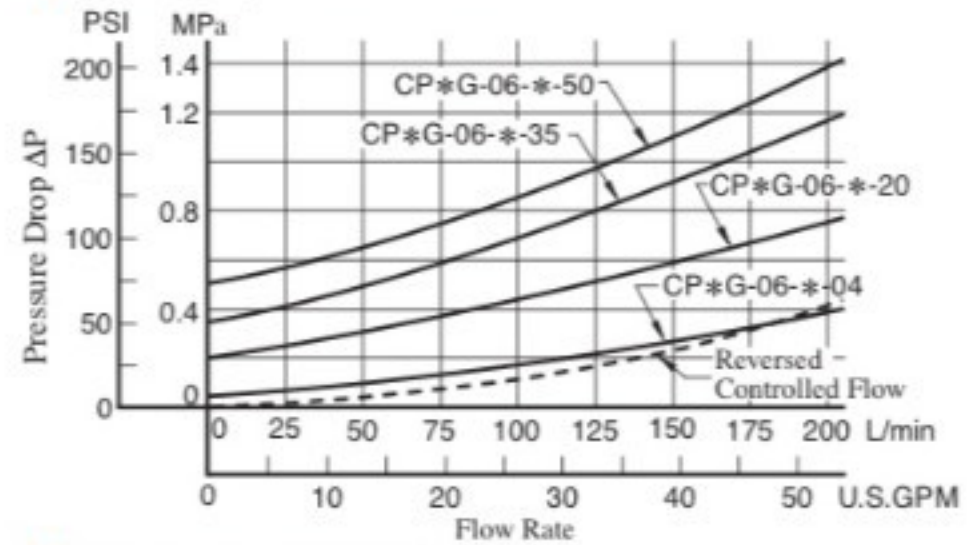

CPT-10, CPDT-10

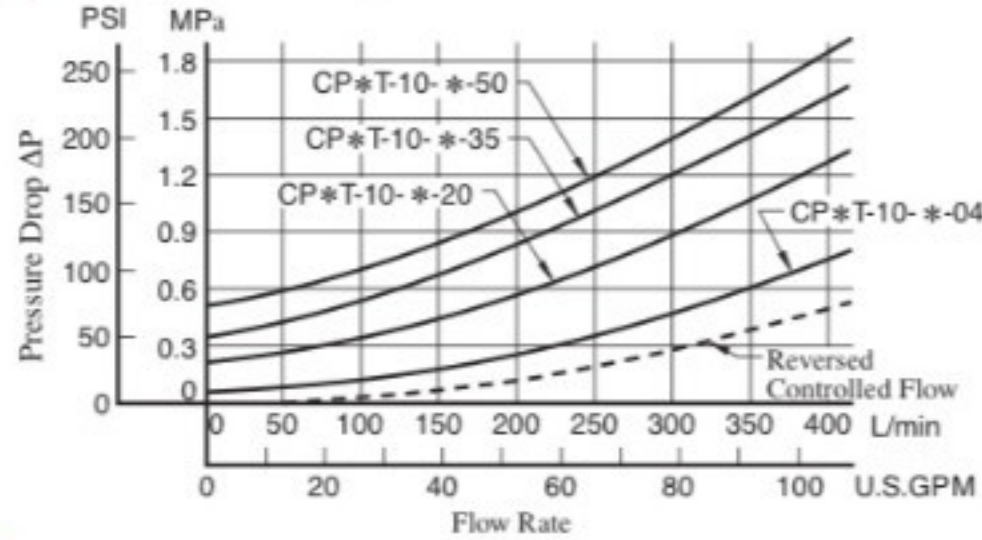

CPG-10, CPDG-10

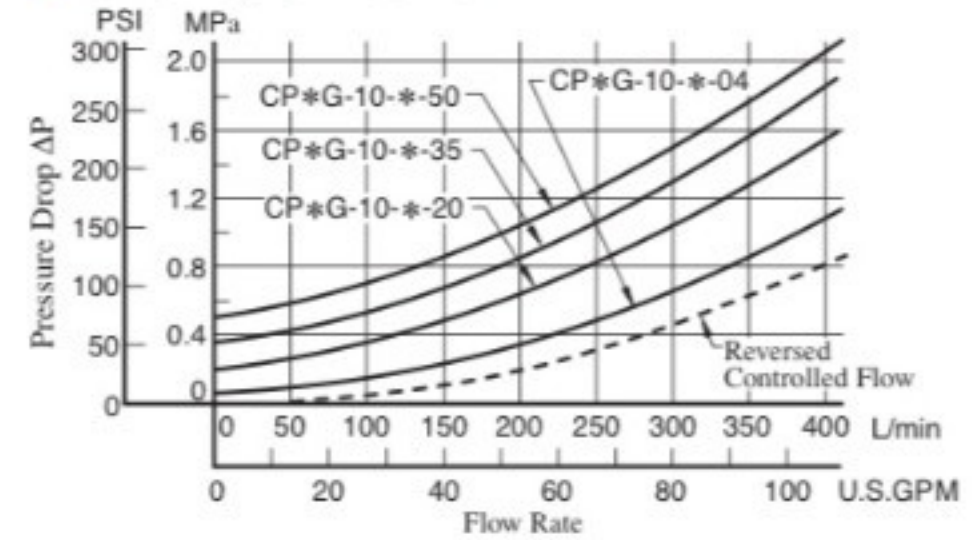

Min. Pilot Pressure Chart

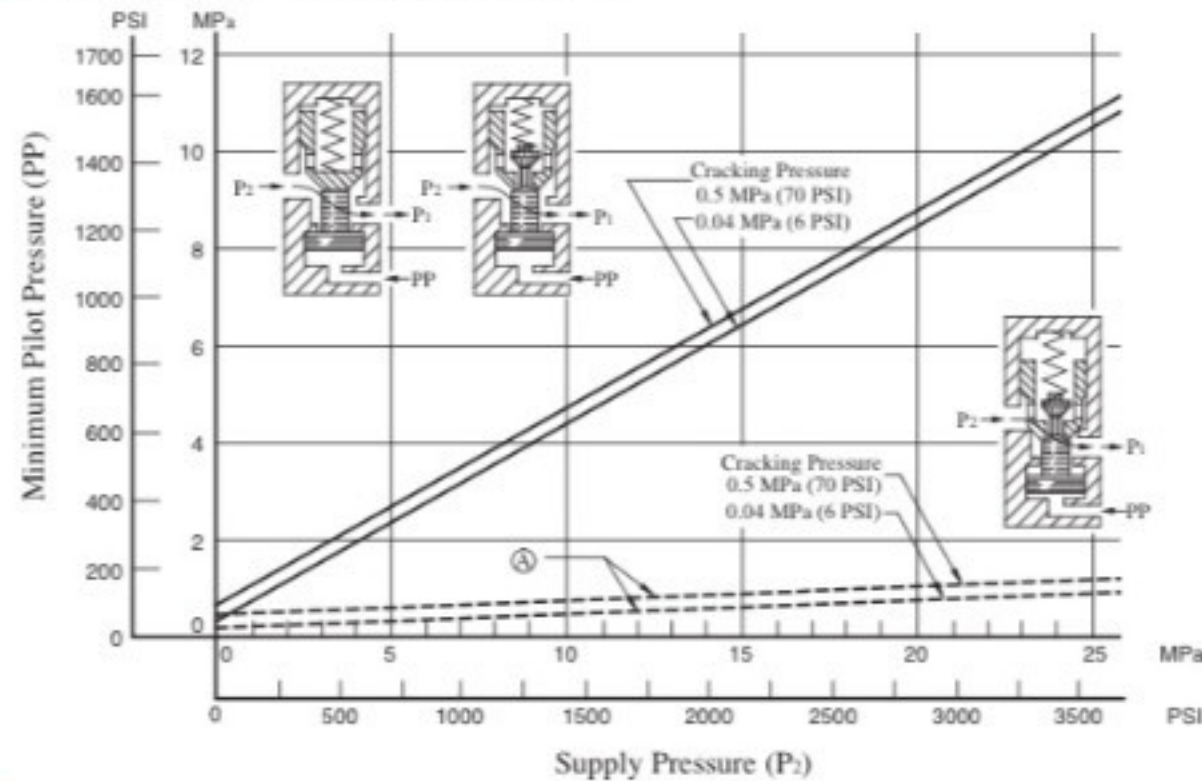

Ⓐ : Min. Pilot Pressure to open the Decompression Valve

Pressure Drop for Reversed Controlled Flow Only when Decompression Valve is Opened

CPDT-03, CPDG-03

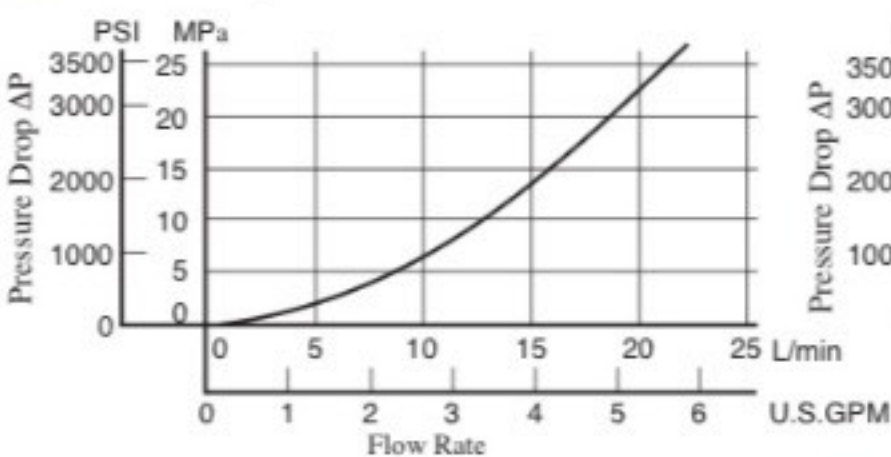

CPDT-06, CPDG-06

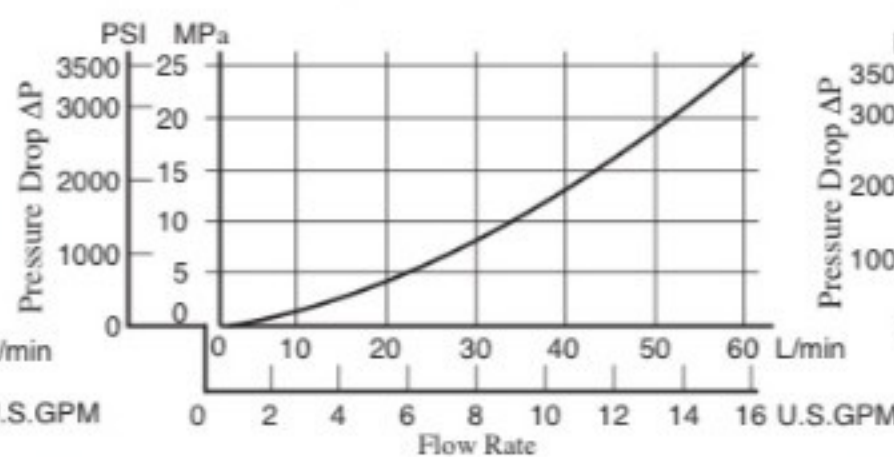

CPDT-10, CPDG-10

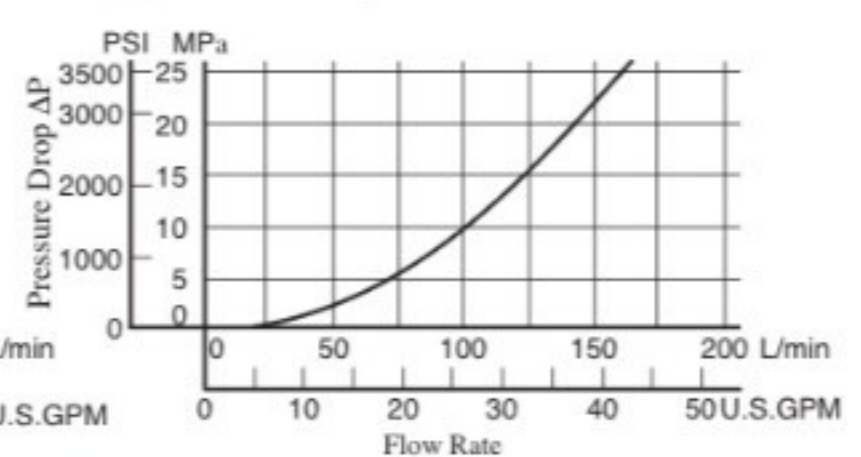

■ List of Seals

CPT/CPDT-03-***-50/5080/5090
 CPT/CPDT-06-***-50/5080/5090
 CPT/CPDT-10-***-50/5080/5090

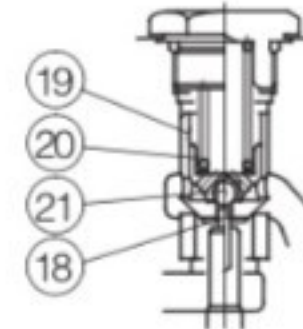
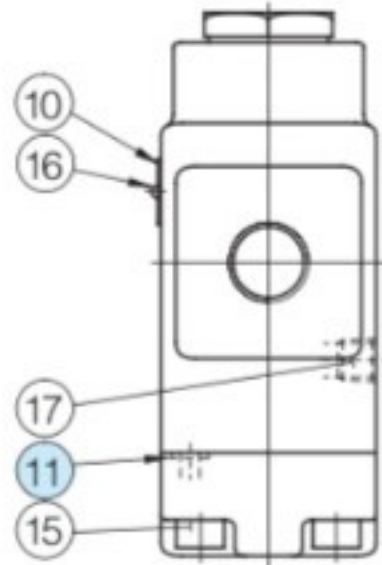
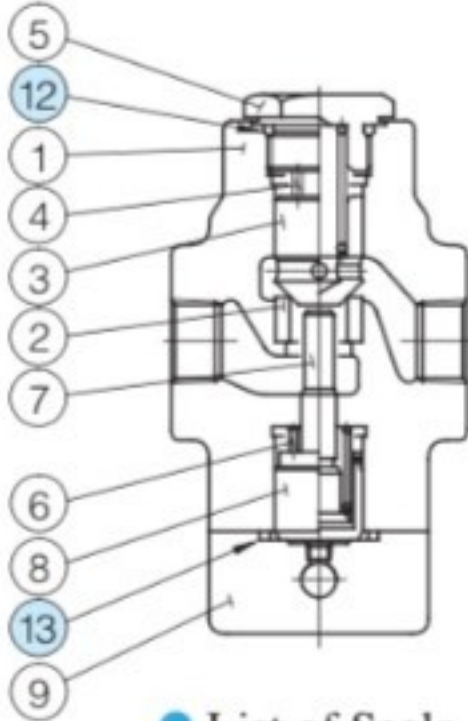

CPDT-03/06/10

● List of Seals

Item	Name of Parts	Part Numbers			Qty.
		CPT/CPDT-03	CPT/CPDT-06	CPT/CPDT-10	
11	O-Ring	SO-NB-P7	SO-NB-P9	SO-NB-P9	1
12	O-Ring	SO-NB-P21	SO-NB-P29	SO-NB-P36	1
13	O-Ring	SO-NB-G25	SO-NB-P32	SO-NB-P42	1

Note: When ordering the seals, please specify the seal kit number from the table below.

CPG/CPDG-03-***-50/5090
 CPG/CPDG-06-***-50/5090
 CPG/CPDG-10-***-50/5090

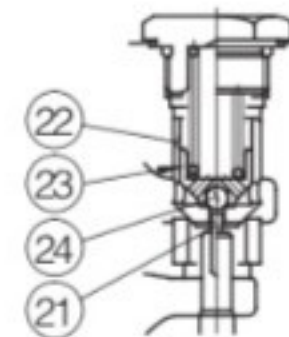
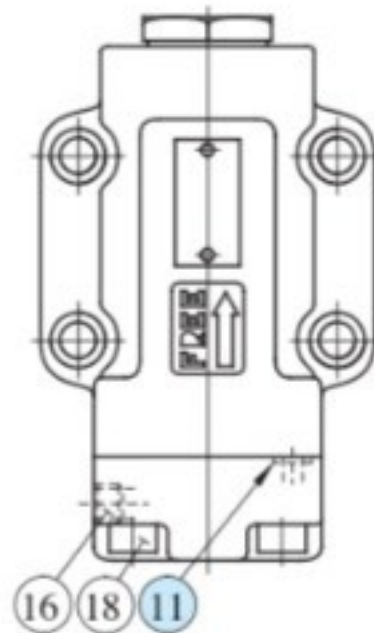
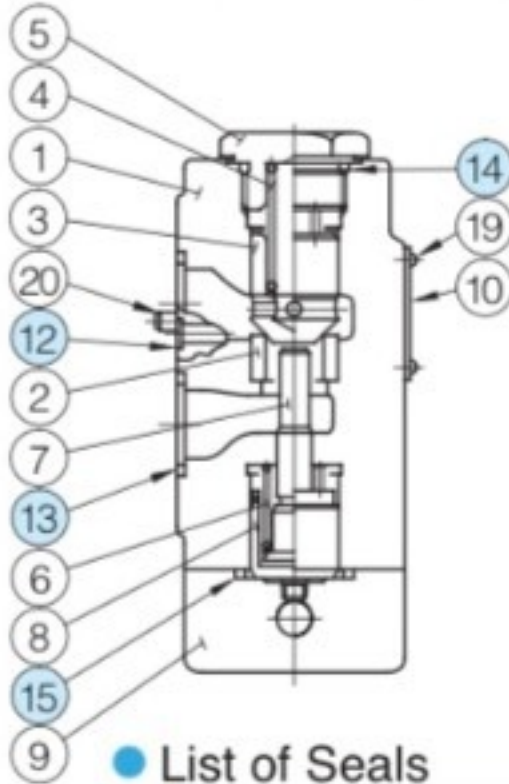

CPDG-03/06/10

● List of Seals

Item	Name of Parts	Part Numbers			Qty.
		CPG/CPDG-03	CPG/CPDG-06	CPG/CPDG-10	
11	O-Ring	SO-NB-P7	SO-NB-P9	SO-NB-P9	1
12	O-Ring	SO-NB-P9	SO-NB-P9	SO-NB-P9	2
13	O-Ring	SO-NB-P18	SO-NB-P28	SO-NB-P32	2
14	O-Ring	SO-NB-P21	SO-NB-P29	SO-NB-P36	1
15	O-Ring	SO-NB-G25	SO-NB-P32	SO-NB-P42	1

Note: When ordering the O-Rings, please specify the seal kit number from the table below.

● List of Seal Kits

Model Numbers	Seal Kit Numbers
CPT/CPDT-03-***-50/5080/5090	KS-CPT-03-50
CPT/CPDT-06-***-50/5080/5090	KS-CPT-06-50
CPT/CPDT-10-***-50/5080/5090	KS-CPT-10-50
CPG/CPDG-03-***-50/5090	KS-CPG-03-50
CPG/CPDG-06-***-50/5090	KS-CPG-06-50
CPG/CPDG-10-***-50/5090	KS-CPG-10-50

Hydraulic Fluid: Viscosity 30 mm²/s (141 SSU), Specific Gravity 0.850

■ Pressure Drop

● CPT-03, CPDT-03

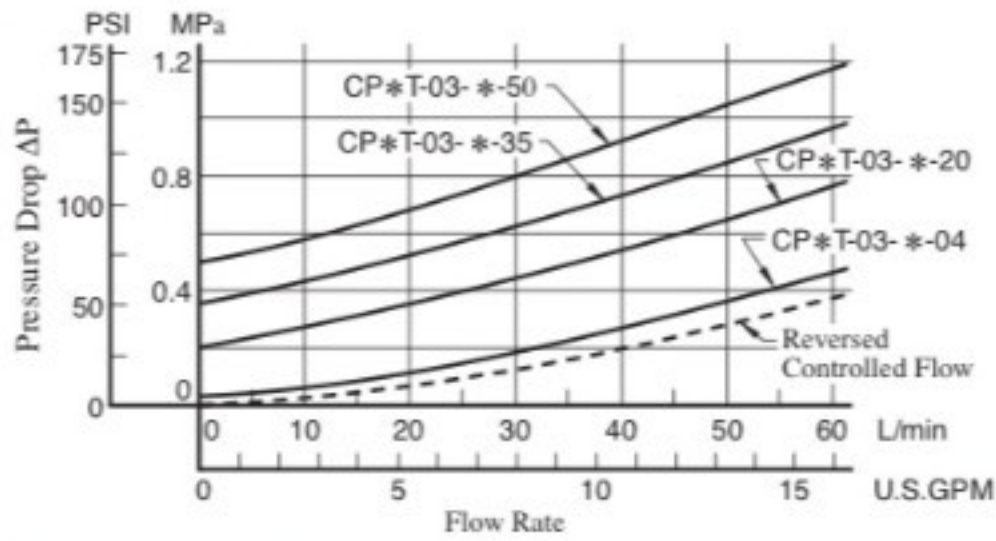

● CPG-03, CPDG-03

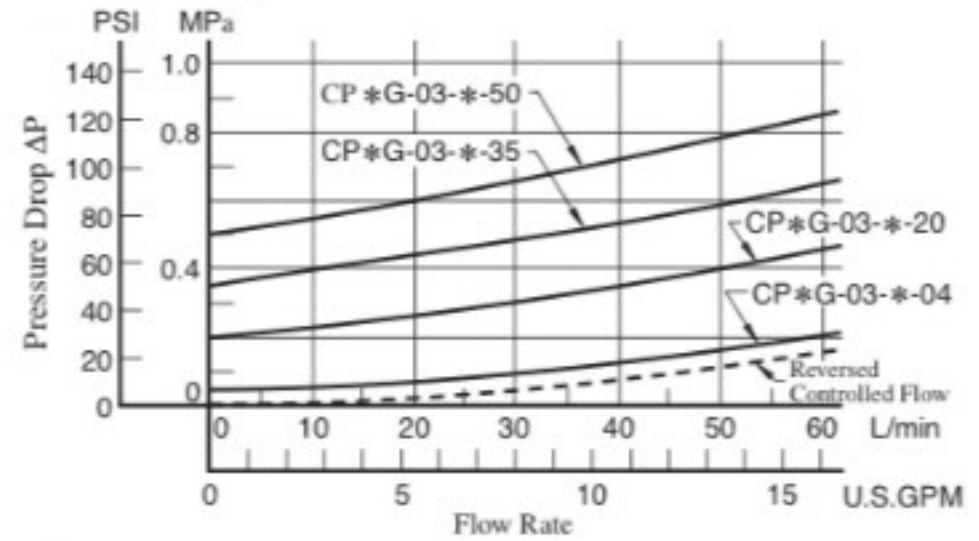

● CPT-06, CPDT-06

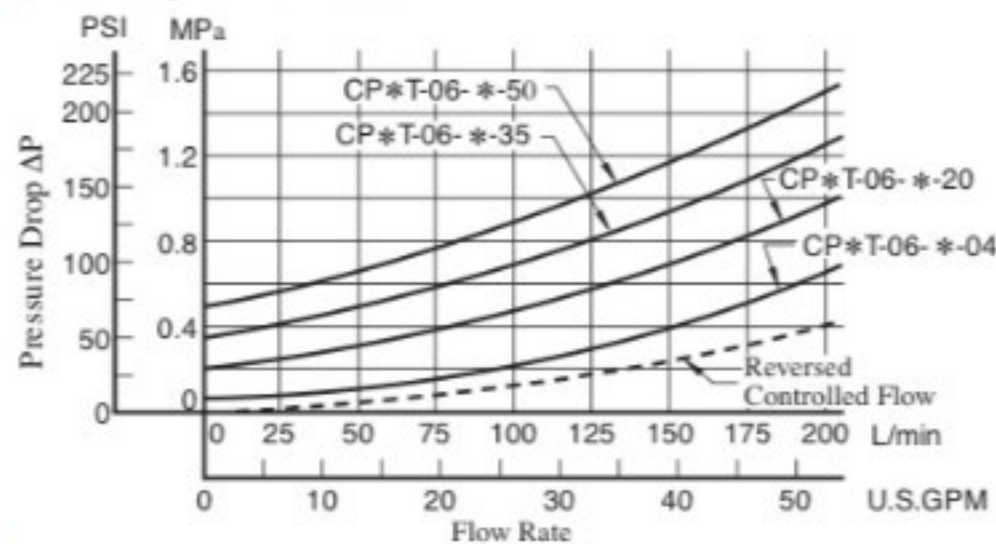

● CPG-06, CPDG-06

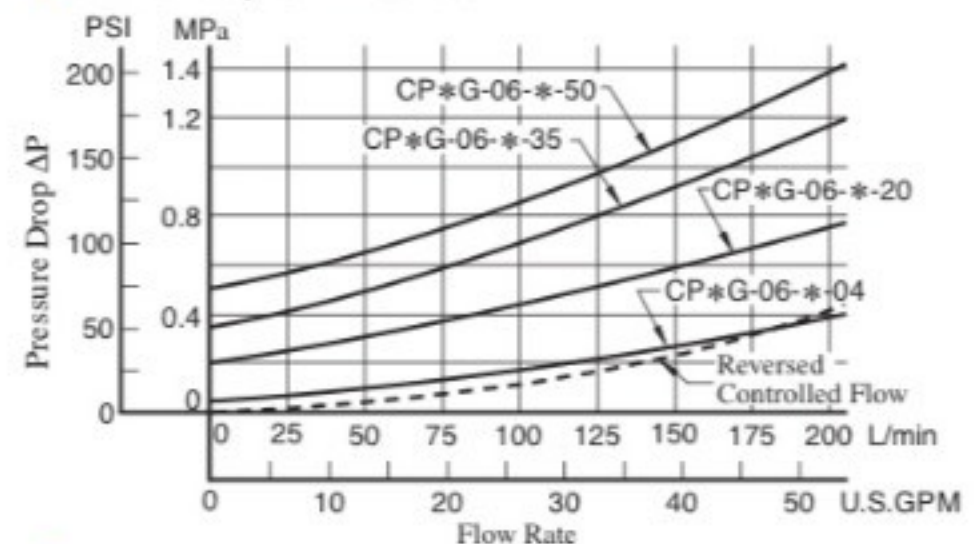

● CPT-10, CPDT-10

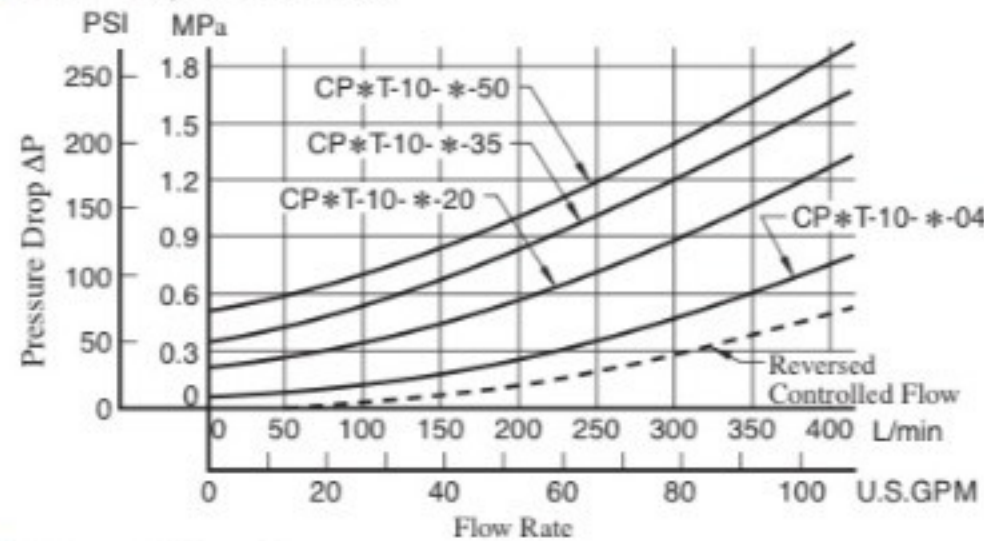

● CPG-10, CPDG-10

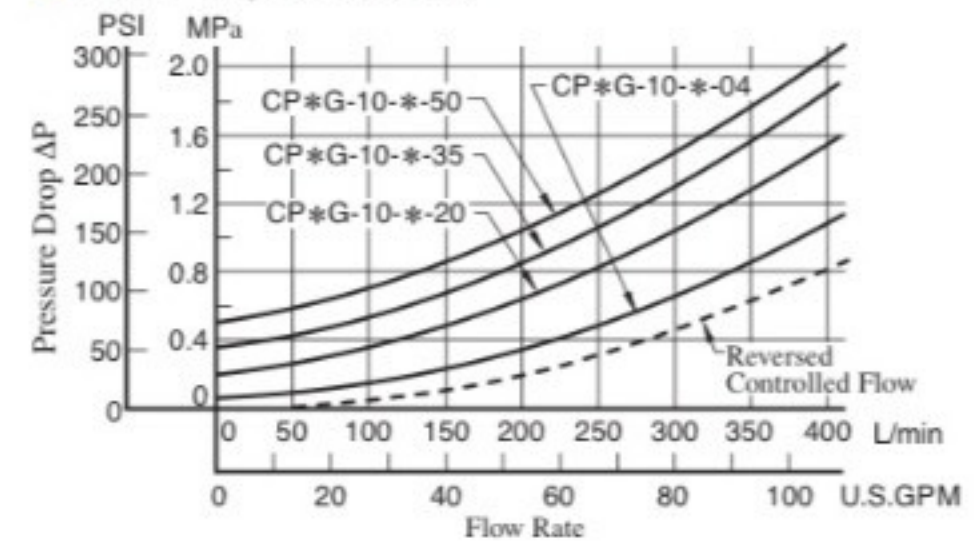

■ Min. Pilot Pressure Chart

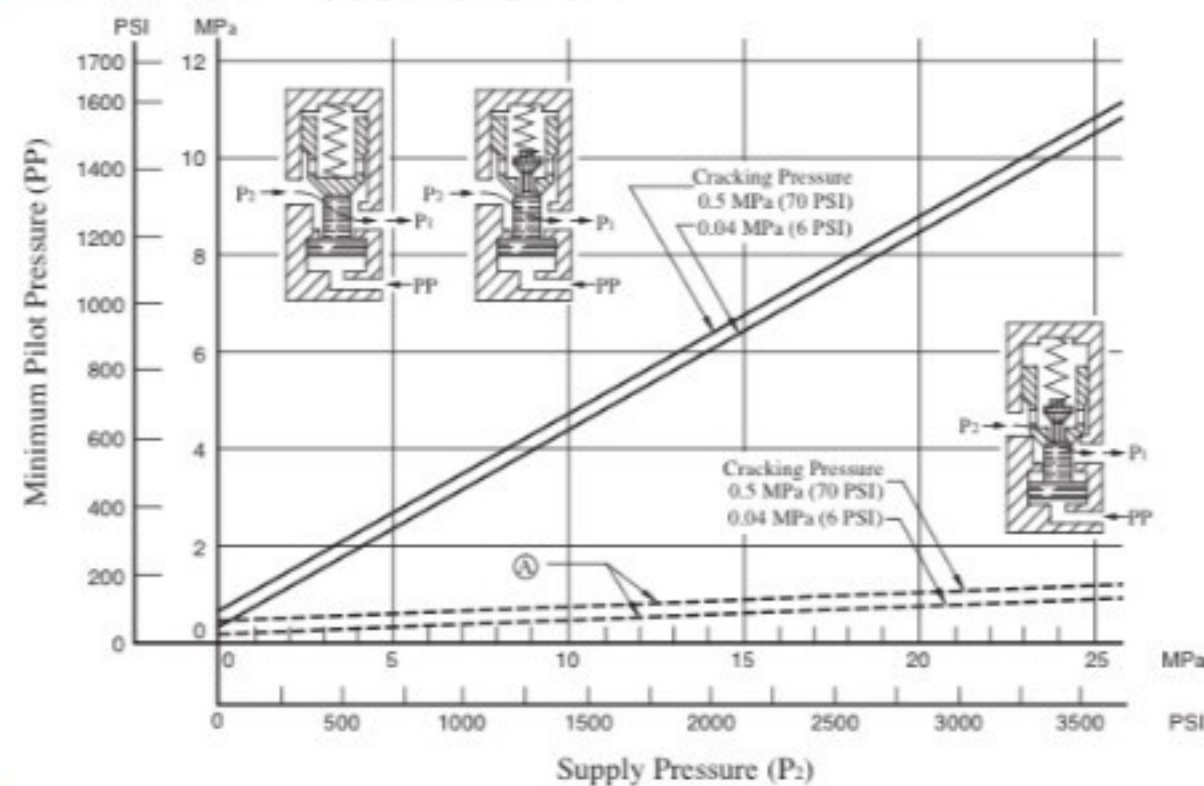

Ⓐ : Min. Pilot Pressure to open the Decompression Valve

■ Pressure Drop for Reversed Controlled Flow Only when Decompression Valve is Opened

● CPDT-03, CPDG-03

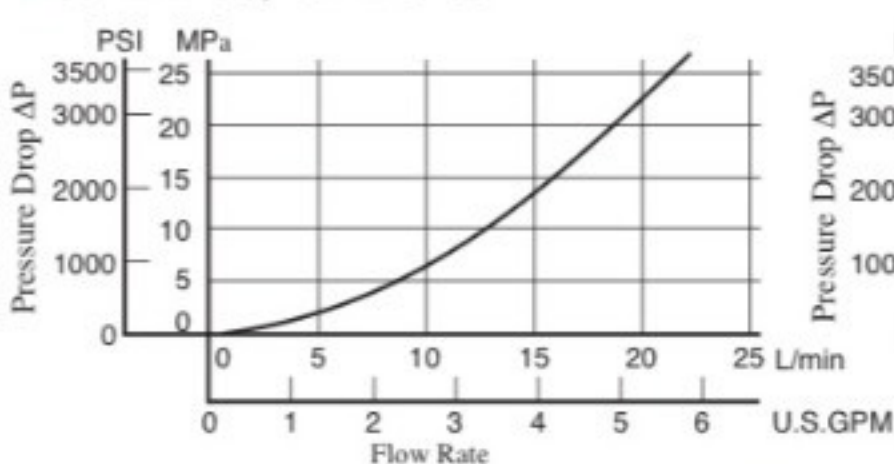

● CPDT-06, CPDG-06

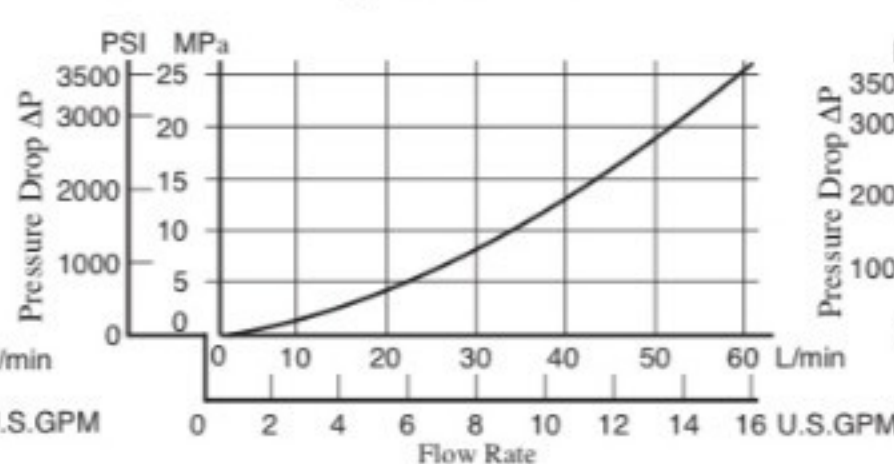

● CPDT-10, CPDG-10

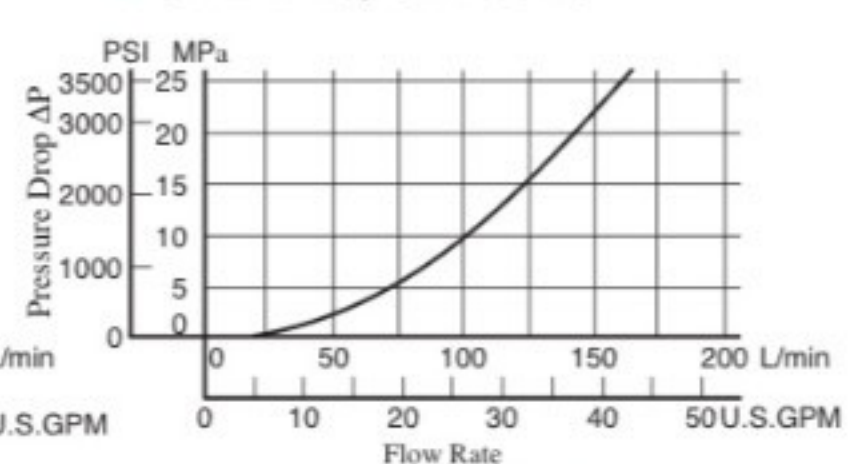

Hydraulic Fluid: Viscosity 30 mm²/s (141 SSU), Specific Gravity 0.850

Pressure Drop

CPT-03, CPDT-03

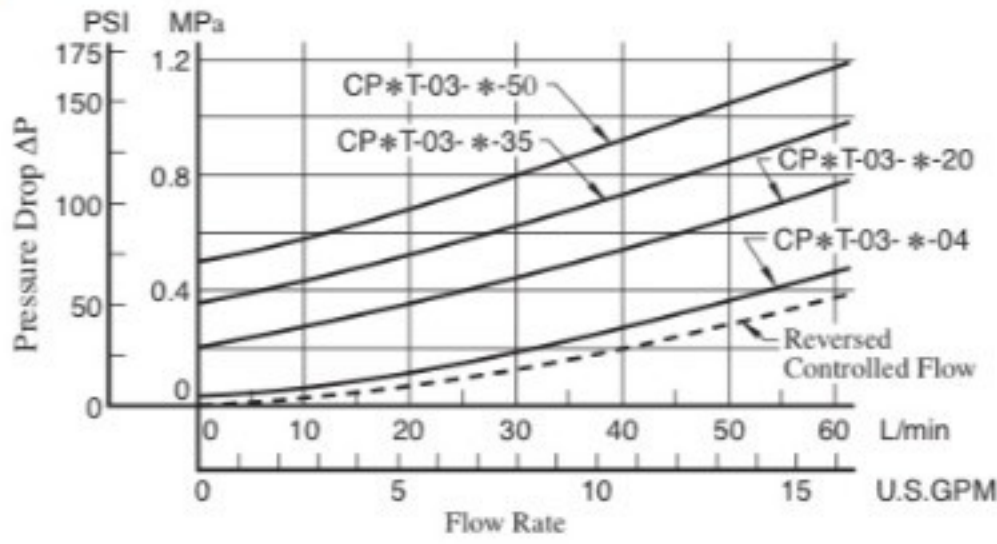

CPG-03, CPDG-03

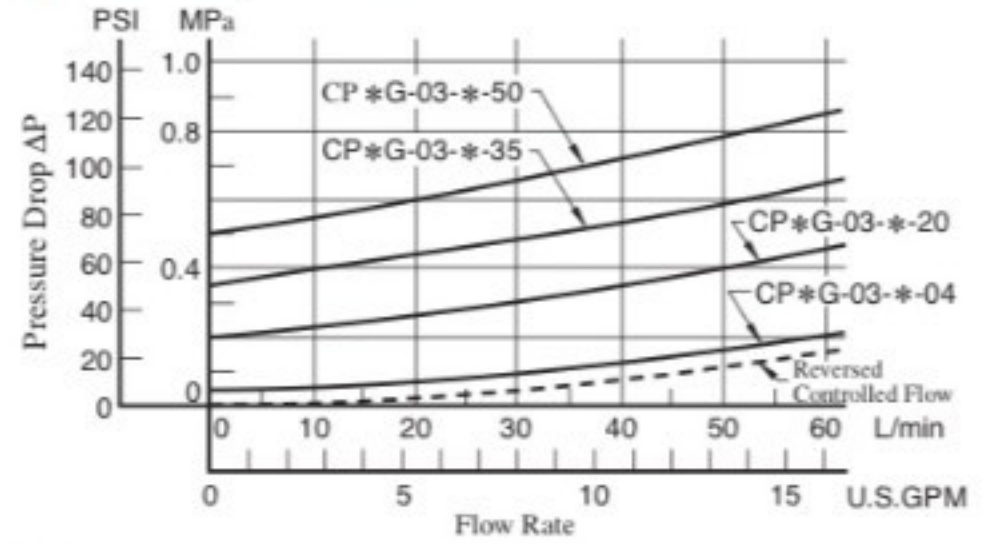

CPT-06, CPDT-06

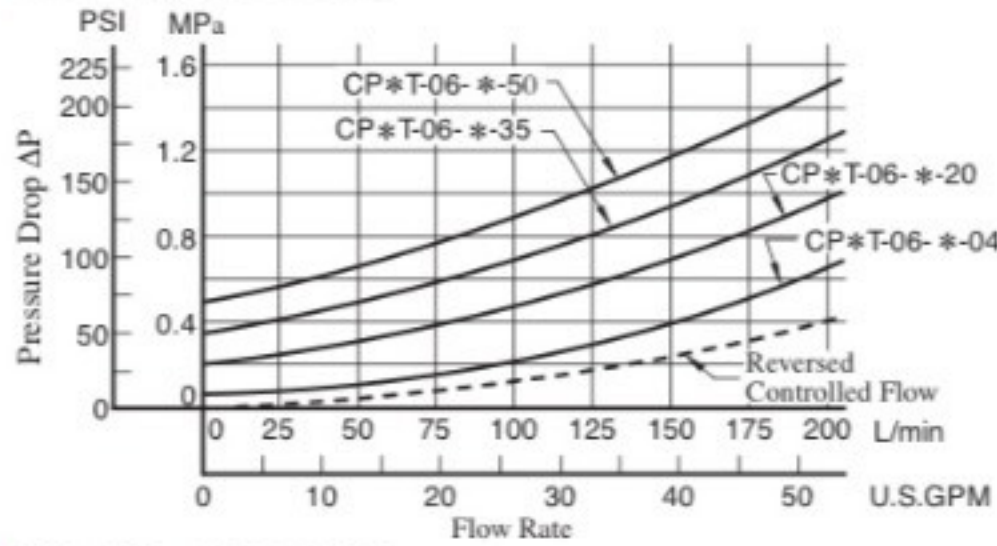

CPG-06, CPDG-06

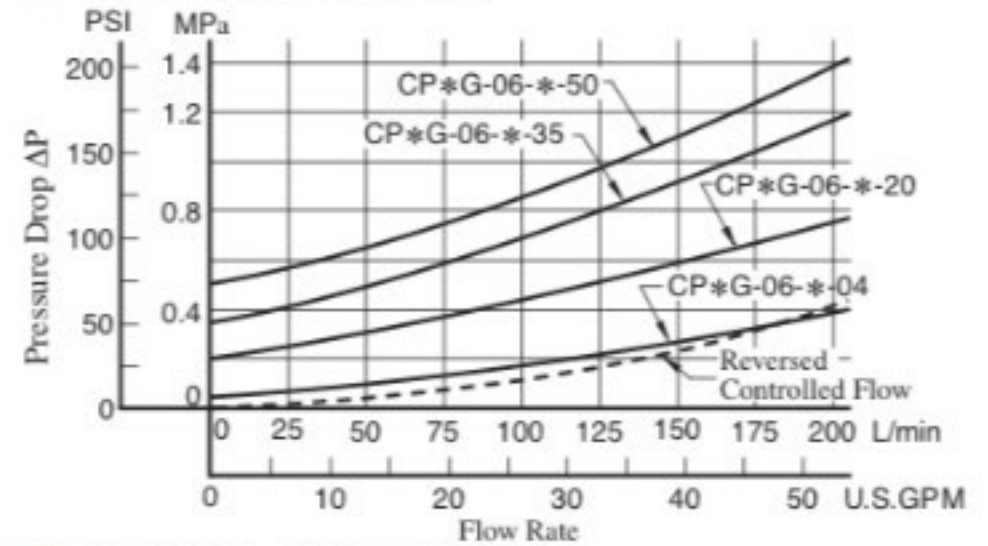

CPT-10, CPDT-10

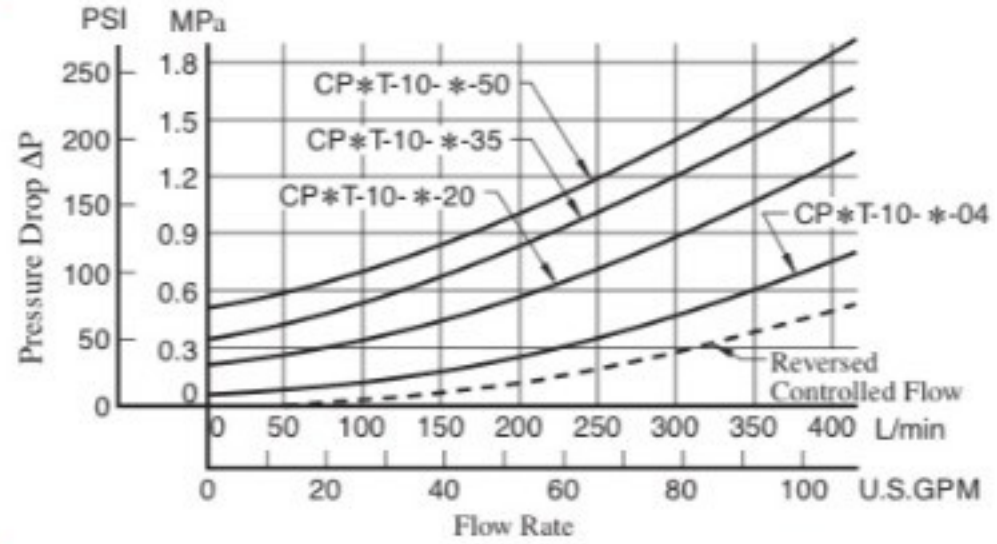

CPG-10, CPDG-10

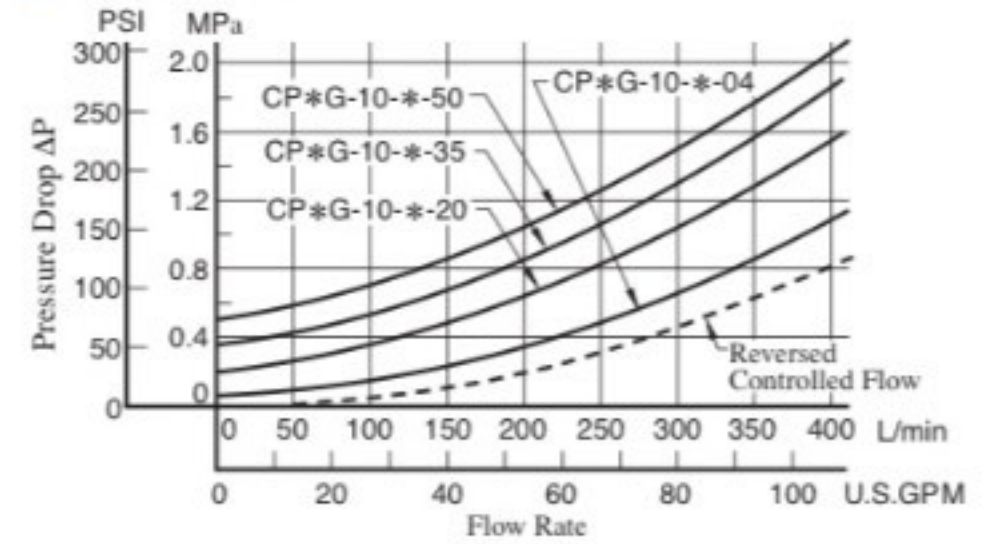

Min. Pilot Pressure Chart

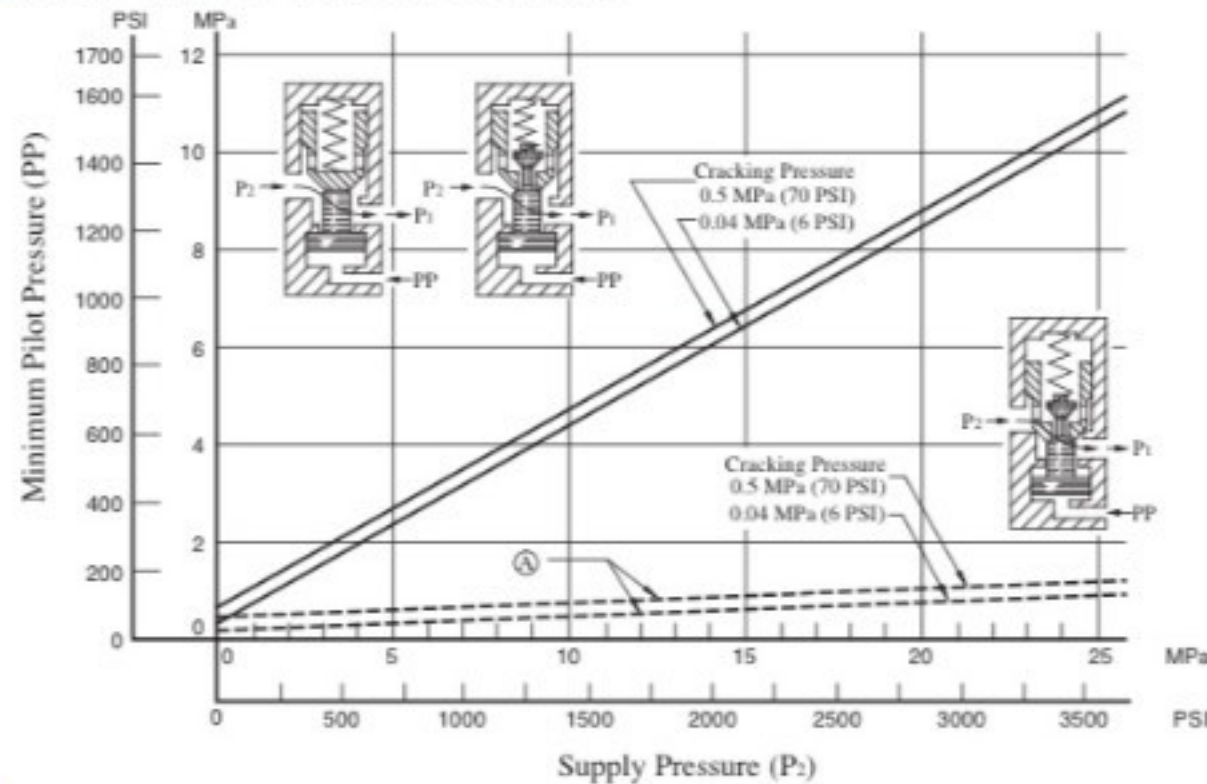

Ⓐ : Min. Pilot Pressure to open the Decompression Valve

Pressure Drop for Reversed Controlled Flow Only when Decompression Valve is Opened

CPDT-03, CPDG-03

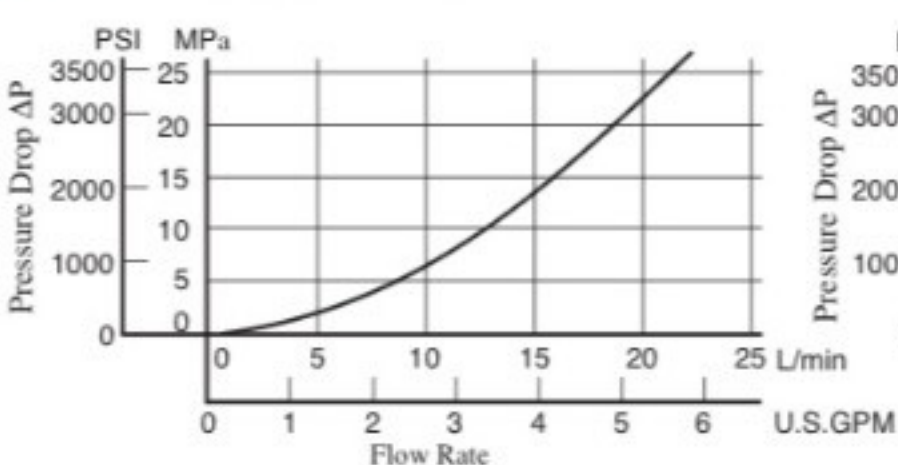

CPDT-06, CPDG-06

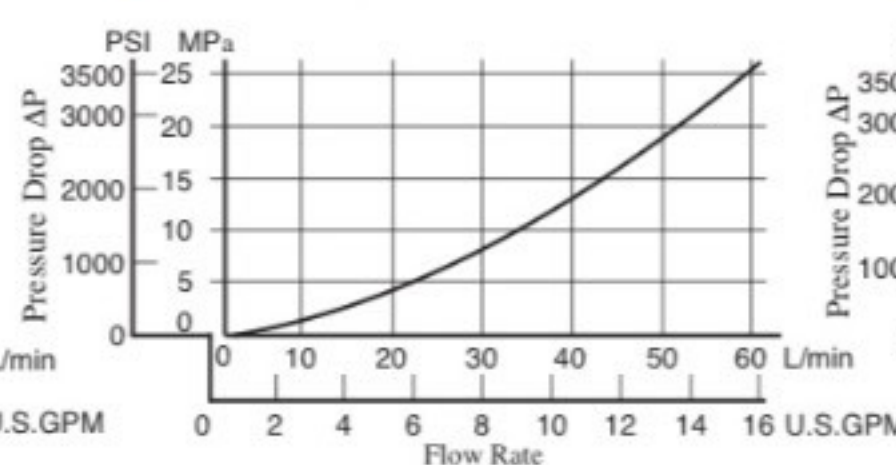

CPDT-10, CPDG-10

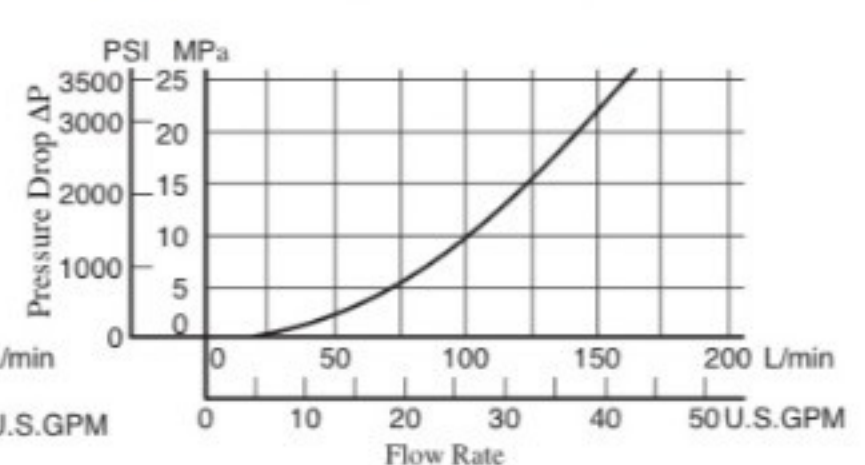

List of Seals

CPT/CPDT-03-*-50/5080/5090
 CPT/CPDT-06-*-50/5080/5090
 CPT/CPDT-10-*-50/5080/5090

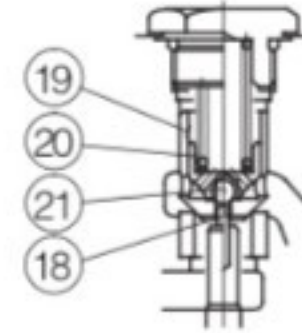
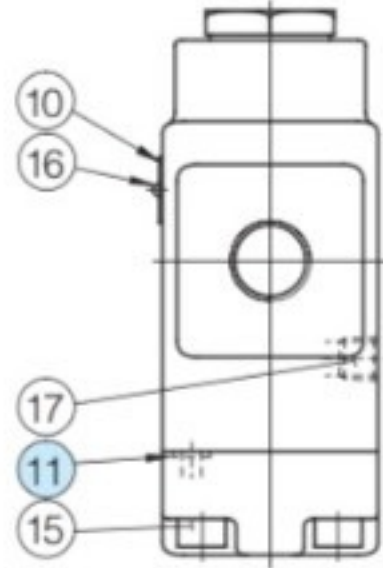
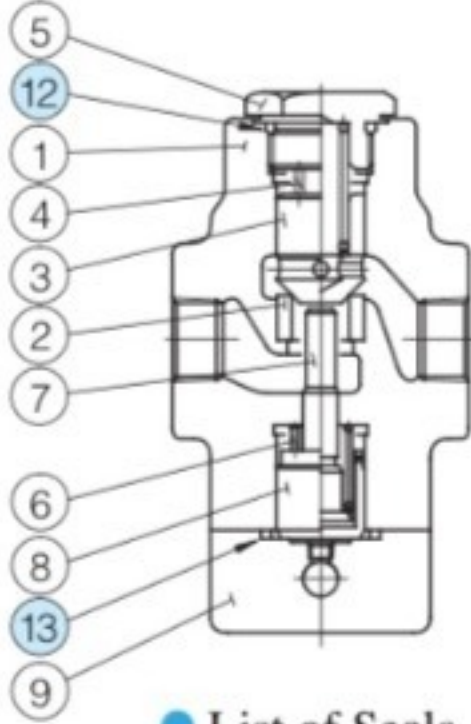

CPDT-03/06/10

List of Seals

Item	Name of Parts	Part Numbers			Qty.
		CPT/CPDT-03	CPT/CPDT-06	CPT/CPDT-10	
11	O-Ring	SO-NB-P7	SO-NB-P9	SO-NB-P9	1
12	O-Ring	SO-NB-P21	SO-NB-P29	SO-NB-P36	1
13	O-Ring	SO-NB-G25	SO-NB-P32	SO-NB-P42	1

Note: When ordering the seals, please specify the seal kit number from the table below.

CPG/CPDG-03-*-50/5090
 CPG/CPDG-06-*-50/5090
 CPG/CPDG-10-*-50/5090

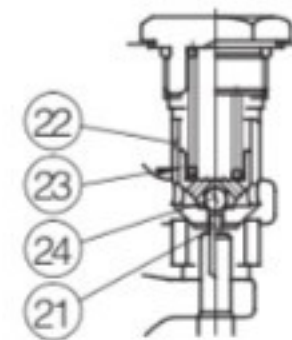
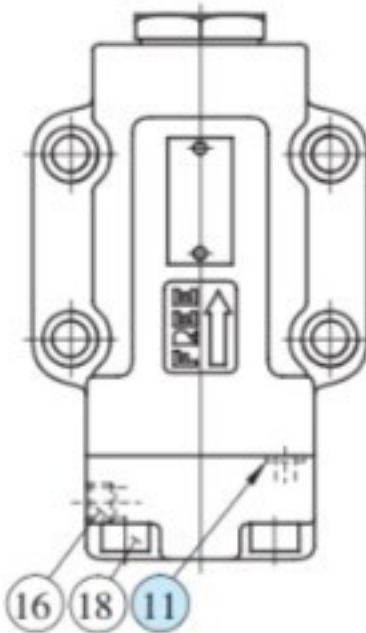
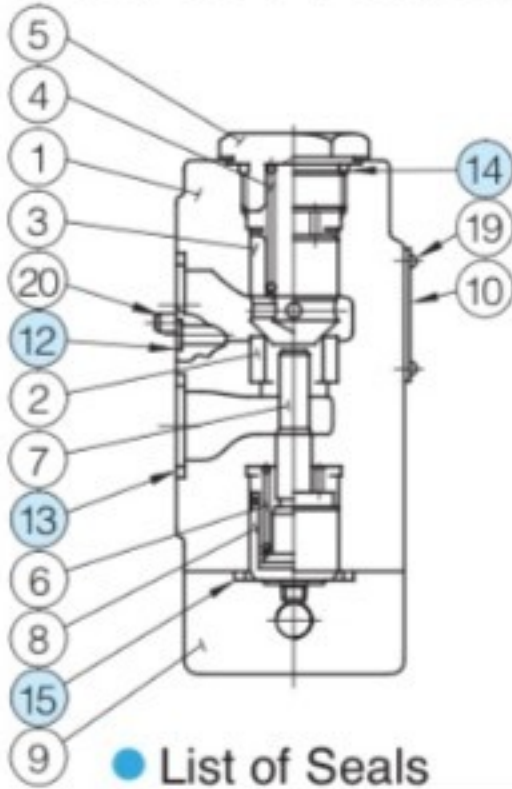

CPDG-03/06/10

List of Seals

Item	Name of Parts	Part Numbers			Qty.
		CPG/CPDG-03	CPG/CPDG-06	CPG/CPDG-10	
11	O-Ring	SO-NB-P7	SO-NB-P9	SO-NB-P9	1
12	O-Ring	SO-NB-P9	SO-NB-P9	SO-NB-P9	2
13	O-Ring	SO-NB-P18	SO-NB-P28	SO-NB-P32	2
14	O-Ring	SO-NB-P21	SO-NB-P29	SO-NB-P36	1
15	O-Ring	SO-NB-G25	SO-NB-P32	SO-NB-P42	1

Note: When ordering the O-Rings, please specify the seal kit number from the table below.

List of Seal Kits

Model Numbers	Seal Kit Numbers
CPT/CPDT-03-*-50/5080/5090	KS-CPT-03-50
CPT/CPDT-06-*-50/5080/5090	KS-CPT-06-50
CPT/CPDT-10-*-50/5080/5090	KS-CPT-10-50
CPG/CPDG-03-*-50/5090	KS-CPG-03-50
CPG/CPDG-06-*-50/5090	KS-CPG-06-50
CPG/CPDG-10-*-50/5090	KS-CPG-10-50