

DIAPHRAGM ACCUMULATORS

MDA Series

Diaphragm Accumulators



Description

Diaphragm accumulators are a cost effective option for numerous functions involving energy storage, shock absorption or pulsation dampening in a hydraulic or fluid system. They are well suited for applications where smaller fluid volumes and flow rates are adequate and that require or involve:

- Compact design
- Low weight
- Flexible mounting positions
- Extremely quick shock response
- Low cost
- Low lubricity fluids, like water

Diaphragm Accumulators have been successfully applied in both industrial and mobile applications for energy storage, maintaining pressure, leakage compensation, and vehicle hydraulic systems.

MILEHERTZ manufactures two types of diaphragm accumulators:

- Carbon steel diaphragm accumulator (Welded)
- Stainless steel diaphragm accumulator (Welded)

Construction

The welded version has a shell that is electron-beam welded, and therefore cannot be repaired.

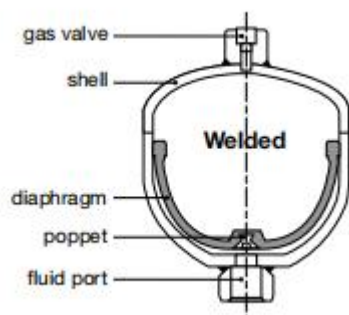

Diaphragm Materials

Not all fluids are compatible with every elastomer at all temperatures, therefore, MILEHERTZ offers the following materials:

- NBR (*Standard Nitrile*)
- HNBR (*Low Temperature Nitrile*)
- IIR (*Butyl*)
- FPM (*Fluoroelastomer*)
- EPDM
- others (available upon request)

Corrosion Protection

For use with certain aggressive or corrosive fluids, or in a corrosive environment, MILEHERTZ offers protective coatings and corrosive resistant materials (*i.e. stainless steel*) for the parts that interface with the fluid or are exposed to the hostile environment.

Mounting Position

Diaphragm accumulators are designed to mount in any position. In systems where contamination is a problem, we recommend a vertical mount with the fluid port oriented downward.

System Mounting

MILEHERTZ diaphragm accumulators are designed to be screwed directly onto the system. We also recommend the use of our mounting components, to minimize the risk of failure due to system vibrations.

Applications

Several applications possible, e.g. in:

- Machines with hydraulic drives
- Presses
- Agricultural- and construction machines
- Modern industrial robots
- Gear Technology
- Braking Systems
- High-pressure cleaner
- Drive hydraulics
- Noise minimization
- Vibration reduction
- Axle suspension
- Driver's cabs

Model Code

MDA 330 - 0.75 - G1/2FM - CN - W

Series

MDA XXX = Diaphragm Accumulator (XXX = series designation)

Size (in Liters, see tables on dimension pages to follow)

0.16	=	0.16Liters
0.25	=	0.25Liters
0.32	=	0.32Liters
0.5	=	0.5Liters
0.75	=	0.75Liters
1.0	=	1.0Liters
1.4	=	1.4Liters
2.0	=	2.0Liters
2.8	=	2.8Liters

Fluid Port Connection

Connect Size For Fluid Port

- M:Metric thread
- U:American thread
- G:Inch unsealed pipe thread
- N:American pipe thread

Connection Type

- F:Female thread
- M:Male thread
- FM:Female and Male thread

Material Code

Shell And Fluid Port

- C:Carbon steel
- S:Stainless steel

Diaphragm

- N:NBR
- H:HNBR
- I:IIR
- E:EPDM
- F:FPM

Compound	Basic Characteristic
NBR	Suitable for most hydraulic fluids
HNBR	Low temperature resistance, wear resistance
IIR	Special for fire resistant hydraulic fluids
EPDM	Corrosion resistance
FPM	High temperature resistance

Shell Construction and Gas Port Design

W:Welded Construction, rechargeable MILEHERTZ Gas valve Version 1(M 28x1.5)

W2:Welded Construction, rechargeable MILEHERTZ Gas valve Version 2(M 14x1.5)

DIAPHRAGM ACCUMULATORS

Dimensions

Non-Repairable Welded Diaphragm Accumulators

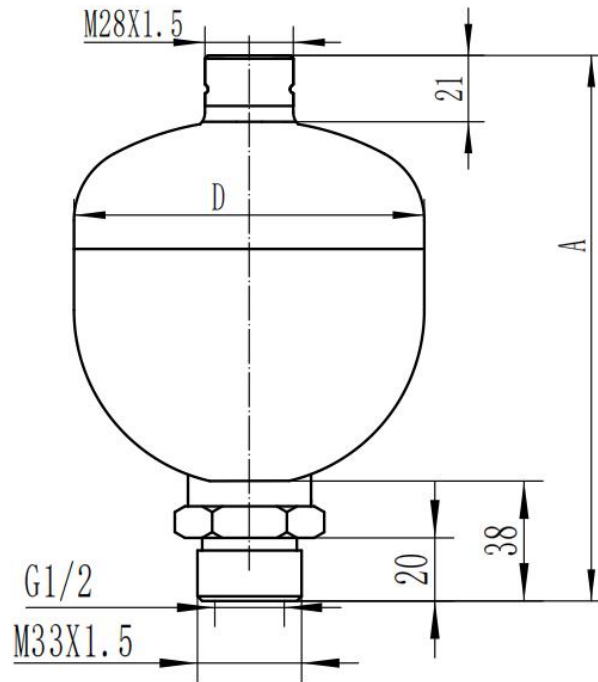

Model	Max Working Pressure (BAR)	Max Working/Charging Pressure	Volume (L)	Weight (KG)	Diameter D(mm)	Overall height A(mm)	Fluid Connection Thread	Max Flow Rate L/min	SW (mm)
MDA	250	8:1	0.16	1.3	75	141	G1/2 female thread and M33X1.5 male thread	38	41
	330		0.25	1.9	89	152			
	330		0.32	2.2	95	158			
	330		0.5	3.0	111	172.8			
	330		0.75	4.3	125	187.5			
	330		1.0	5.5	142	199			
	330		1.4	8.1	157	228			
	330		2.0	10.1	173	252			
	330	4:1	2.8	11.3	173	287		150	

Liquid end interface thread(Carbon steel Accumulators)

Common	British	G1/4 Male/Female thread	G1/2 Male/Female thread	Compound Pad
		G3/8 Male/Female thread	G3/4 Female thread	
	US	9/16-18UNF Male/Female thread	3/4-16UNF Male/Female thread	
		7/8-14UNF Male/Female thread	1 1/16-12UNF Female thread	
	Metric	M14X1.5 Male/Female thread	M18X1.5 Male/Female thread	
M16X1.5 Male/Female thread		M22X1.5 Male/Female thread		
Combination	G1/2 Female thread AND M33X1.5 Male thread	G3/4 Female thread AND M45X1.5 Male thread		
Optional		Metric (M) British (G) American Unified (UNF) American Pipe (NPT) Internal and External Double Thread (G+M, M+M, UNF+M)		O-Ring /ED-Ring

Dimensions are general information only, all critical dimensions should be verified. Dimensions are in millimeter and kilogram.