

Axial piston variable pump A4VSO

RE 92050/04.09 1/68
Replaces: 03.09

Data sheet

Series 10, 11 and 30
Size 40...1000
Nominal pressure 350 bar
Peak pressure 400 bar
Open circuit



Contents

Type code for Standard program	2
Technical data	5
Characteristics	10
Summary of controls	13
Dimensions, size 40	18
Dimensions, size 71	20
Dimensions, size 125	22
Dimensions, size 180	24
Dimensions, size 250	26
Dimensions, size 355	28
Dimensions, size 500	30
Dimensions, size 750	32
Dimensions, size 1000	36
Through drive	38
Summary mounting options on A4VSO	39
Permissible mass bending moment	40
Dimensions combination pumps	41
Dimensions through drive	43
Installation notes	66
General information	68

Features

- Axial piston pump in swash plate design for hydrostatic drives in open circuit operation
- The flow is proportional to the input drive speed and displacement. By adjusting the swash plate angle it is possible to infinitely vary the output flow.
- Excellent suction characteristics
- Low noise level
- Long service life
- Modular design
- Short response times
- Variable through drive options
- Visual swivel angle indicator
- Optional mounting position
- Operation on HF-fluids under reduced operational data possible

A special version is available for operation with HFC-fluid see data sheet RE 92053

For the descriptions of the control devices see the separate RE data sheets

RE 92056, RE 92060, RE 92064,
RE 92072, RE 92076, RE 92080, RE 92088

	A4VS		O			/			-						
01	02	03	04	05	06		07	08		09	10	11	12	13	14

Hydraulic fluid / Version

		40	71	125	180	250	355	500	750	1000	
01	Mineral oil and HFD-fluids (no code)	●	●	●	●	●	●	●	●	●	
	HFA-, HFB- and HFC-Fluids	●	●	-	-	-	-	●	-	-	E
	For operation on HFC-special performance version see RE 92053 (HFA and HFB see RE 90223)			●	●	●	●				
	High-Speed-Version	-	-	-	-	●	●	●	-	-	H

Axial piston unit

02	Swash plate design, variable															A4VS
----	------------------------------	--	--	--	--	--	--	--	--	--	--	--	--	--	--	------

Boost pump (Impeller)

		40	71	125	180	250	355	500	750	1000	
03	without boost pump (no coden)	●	●	●	●	●	●	●	●	●	
	with boost pump (Impeller) only with port plate 25 (service port connections)	-	-	-	-	-	-	-	●	-	L

Type of operation

04	Pump, open circuit															O
----	--------------------	--	--	--	--	--	--	--	--	--	--	--	--	--	--	---

Size

		40	71	125	180	250	355	500	750	1000
05	Displacement $V_{g \max}$ [cm ³]	40	71	125	180	250	355	500	750	1000

Control devices

		40	71	125	180	250	355	500	750	1000	
06	Pressure control	●	●	●	●	●	●	●	●	●	DR..
	Pressure control for parallel operation (RE 92060)	●	●	●	●	●	●	●	●	●	DP..
	Flow control	●	●	●	●	●	●	-	-	-	FR..
	Pressure and flow control	●	●	●	●	●	●	-	-	-	DFR..
	Power control with hyperbolic curve (RE 92064)	●	●	●	●	●	●	●	●	●	LR.. ¹⁾
	Manual control (RE 92072)	●	●	●	●	●	●	●	-	-	MA..
	Electric motor control	●	●	●	●	●	●	●	-	-	EM..
	Hydraulic control, control volume dependent	●	●	●	●	●	●	●	●	●	HM..
	Hydr. control, with servo/proportional valve (RE 92076)	●	●	●	●	●	●	●	●	●	HS.. ¹⁾
	Electronic control	●	●	●	●	●	●	●	●	●	EO.. ¹⁾
	Hydraulic control, pilot pressure dependent (RE 92080)	● ²⁾	● ²⁾	●	●	●	●	●	●	●	HD.. ¹⁾
	Secondary speed control (RE 92056)	●	●	●	●	●	●	●	●	○	DS1.. ¹⁾
	Electro-hydraulic control system DFE1 (RE 92088) System solution SYHDFEE (RE 30035)	●	●	●	●	●	●	-	-	-	DFE1.. ¹⁾

Series

		40	71	125	180	250	355	500	750	1000	
07		●	●	-	-	-	-	-	-	-	10(11) ²⁾
		-	-	●	●	●	●	●	●	●	30

● available ○ in preparation - not available

= preferred program

¹⁾ when operating on HF-fluids, observe the limitations as shown in the relevant data sheets of the control devices and the mounted valves

²⁾ Versions with HD-controls only in series 11

	A4VS		O			/			-						
01	02	03	04	05	06		07	08		09	10	11	12	13	14

Direction of rotation

08	with view on shaft end	right hand	R
		left hand	L

Seals

		40	71	125	180	250	355	500	750	1000	
09	NBR (Nitrile-rubber), Shaft seal FKM (Fluoro-rubber)	●	●	●	●	●	●	●	●	●	P
	FKM (Fluoro-rubber) / for operation on HFD	●	●	●	●	●	●	●	●	●	V
	HFC-special performance version see RE 92053	-	-	●	●	●	●	-	-	-	F

Shaft end

10	Keyed parallel shaft to DIN 6885	P
	Splined shaft to DIN 5480	Z

Mounting flange

		40	71	125	180	250	355	500	750	1000	
11	similar to ISO 3019-2 metric	4-hole	●	●	●	●	●	-	-	-	B
		8-hole	-	-	-	-	-	●	●	●	H

Service line connections

		40	71	125	180	250	355	500	750	1000	
12	Port B and S: SAE flange on side, 90° offset, metric fixing screws	●	●	●	●	●	●	-	-	-	13 ¹⁾
	Port B and S: SAE flange on side, 90° offset, metric fixing screws 2. pressure port B ₁ , opposite B – closed with blanking plate on delivery	●	●	●	●	●	●	●	●	●	25

● available ○ in preparation = preferred program

¹⁾ only with through drive code N00 and K..

Series 1

(Example: pressure control; for exact dimensions of the control devices see separate data sheets)

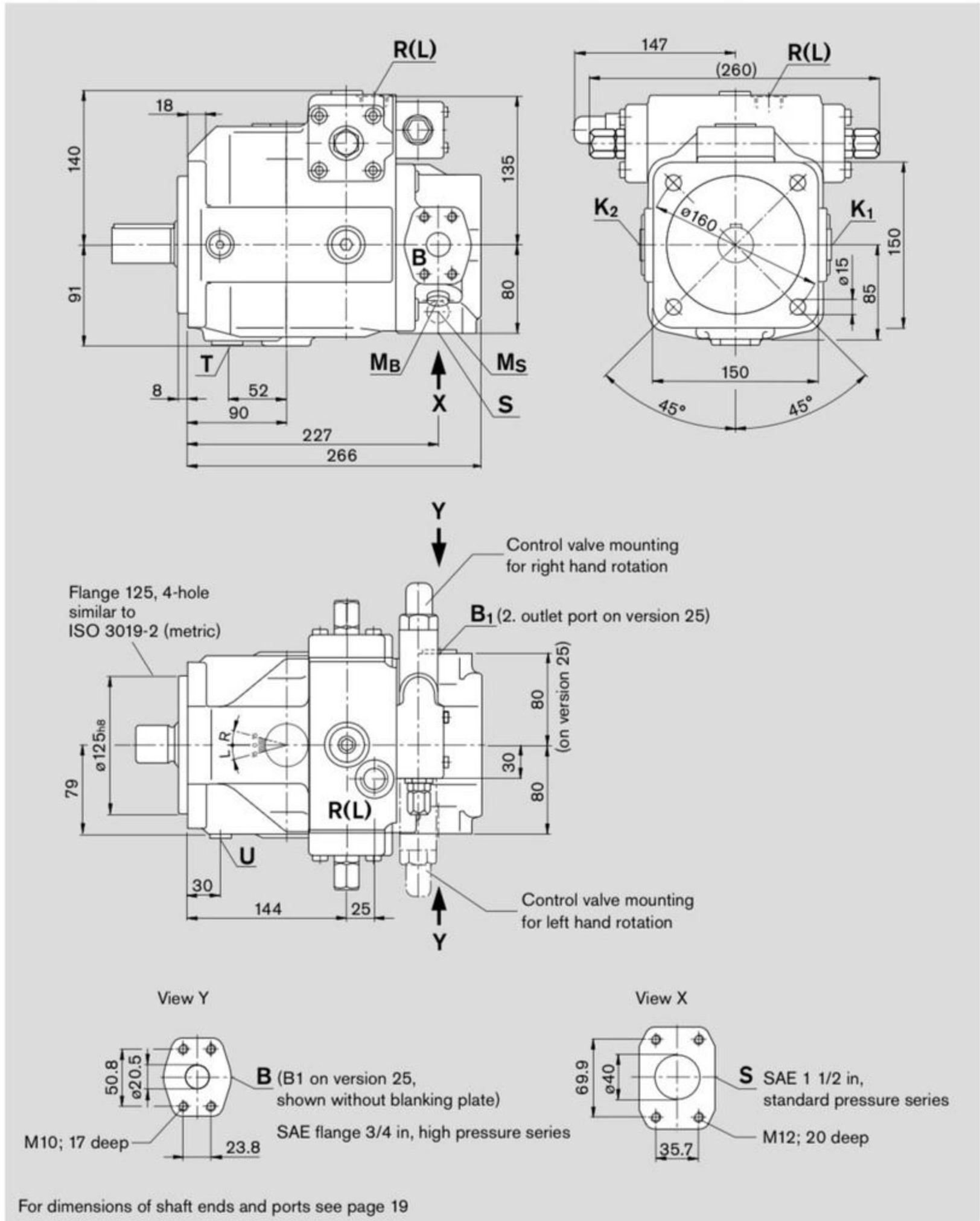

For dimensions of shaft ends and ports see page 19