

# RE 21 468/06.02

Replaces: 10.95

## Check valve; hydraulically pilot operated Types SV and SL

Nominal sizes 10 to 32

Series 4X

Maximum operating pressure 315 bar

Maximum flow 550 L/min



H5558

Type SL 25 GA.-4X/... and SV 10 PA.-4X...

### Overview of contents

Contents	Page
Features	1
Ordering details	1
Preferred types	1
Symbols	2
Function, section	2
Technical data	3
Characteristic curves	4
Unit dimensions	5 and 6

### Features

- For subplate mounting, porting pattern to DIN 24 340 form D, ISO 5781 and CETOP–RP 121 H, subplates to catalogue sheet RE 45 062 (separate order), see page 5
- For threaded connections
- With or without drain port
- With or without decompression feature
- Type with decompression, dampened decompression (minimising possible pressure shocks)
- 4 opening pressures, optional

### Ordering details

					S					-4X/	*	
<b>Without</b> drain port					= V							Further details in clear text
<b>With</b> drain port					= L							
Type	SV		SL									No code = NBR seals V = FKM seals (other seals on request) <b>⚠ Attention!</b> The compatibility of the seals and pressure fluid has to be taken into account!
Connection type	G	P	G	P								
Ordering details												4X = Series 40 to 49 (40 to 49: unchanged installation and connection dimensions)
Nom. size 10	= 10	= 10	= 10	= 10								
Nom. size 16	= 15	—	= 15	—								
Nom. size 20	= 20	= 20	= 20	= 20								
Nom. size 25	= 25	—	= 25	—								
Nom. size 32	= 30	= 30	= 30	= 30								
For subplate mounting					= P							1 = } 2 = } 3 = } 4 = } <b>Opening pressure</b> See $\Delta p-q_v$ -characteristic curves A to B
For threaded connections					= G							
<b>With</b> decompression feature					= A							
<b>Without</b> decompression feature					= B							



© 2002  
by Bosch Rexroth AG, Industrial Hydraulics, D-97813 Lohr am Main

All rights reserved. No part of this document may be reproduced or stored, processed, duplicated or circulated using electronic systems, in any form or by any means, without the prior written authorisation of Bosch Rexroth AG. In the event of contravention of the above provisions, the contravening party is obliged to pay compensation.

This document was prepared with the greatest of care, and all statements have been examined for correctness. This document is subject to alterations for reason of the continuing further developments of products. No liability can be accepted for any incorrect or incomplete statements.

## Preferred types (readily available)

Type SL	Material No.
SL 10 GA1-4X/	00483370
SL 10 PA1-4X/	00483371
SL 15 GA1-4X/	00587553
SL 20 GA1-4X/	00587554
SL 20 PA1-4X/	00587559
SL 25 GA1-4X/	00587555
SL 30 GA1-4X/	00587556
SL 30 PA1-4X/	00587560

Type SV	Material No.
SV 10 GA1-4X/	00483368
SV 10 GB1-4X/	00453511
SV 10 PA1-4X/	00483369
SV 15 GA1-4X/	00587549
SV 20 GA1-4X/	00587550
SV 20 PA1-4X/	00587557
SV 30 PA1-4X/	00587558

**Preferred types and standard components are highlighted in the RPS (Standard Price list).**

## Function, section, symbols

The SV and SL valves are hydraulic pilot operated check valves of poppet type design which may be opened to permit flow in the reverse direction.

These valves are used for the isolation of operating circuits which are under pressure, i.e. as a safe guard against the lowering of a load when a line break occurs or against creeping movements of hydraulically locked actuators.

The valve basically comprises of the housing (1), the poppet (2), a compression spring (3), the control spool (4) as well as an optional decompression feature as a ball poppet valve (5).

The valve permits free-flow from A to B. In the reverse direction, the poppet (2) is held firmly on to its seat in addition to the spring force by the system pressure.

By applying pressure to pilot connection X, the control spool (4) is moved to the right. This lifts poppet (2) off its seat, now the valve also permits free-flow from B to A.

In order to ensure that the valve opens due to pressure applied to the control spool (4), a certain minimum pilot pressure is required (see page 2).

### Types SV..A.. and SL..A.. (with decompression, section 1)

This valve is fitted with an additional decompression feature. When pressure is applied to port X, the control spool (4) is moved to the right. This firstly lifts the ball (5.1) and then the poppet (2) off their seats. The valve now permits flow from B to A.

Because of the decompression feature there is a dampened decompression of the pressurised fluid. Due to this possible pressure shocks are avoided.

### Type SL... (with drain connection, section 2)

In principle, the function of this valve corresponds to that of the type SV.

The difference lies in the additional drain port Y. Here, the annular area of the control spool (4) is separated from the port A. Pressure present in port A acts only on area  $A_4$  (9) of the control spool (4).

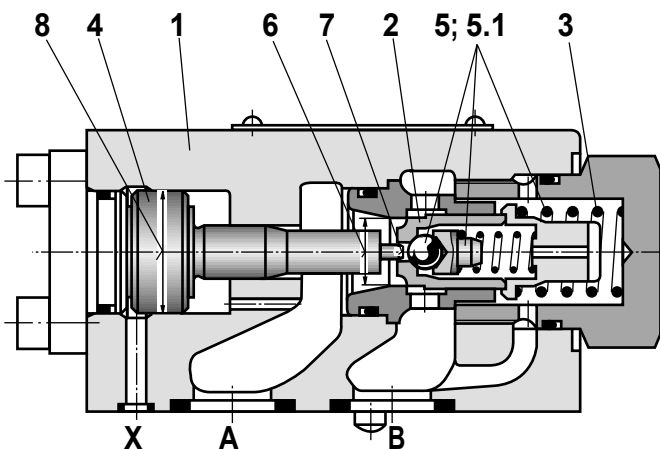

Section 1  
Type SV..PA.-4X/... (without drain port, **with** decompression)

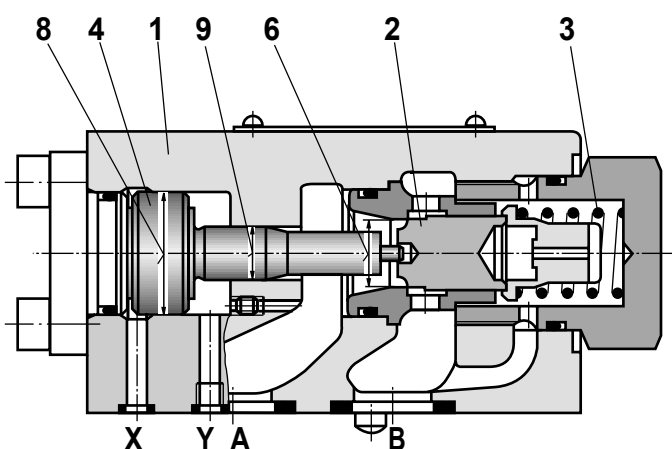

Section 2  
Type SL..PB.-4X/... (**with** drain port, without decompression)

## Symbols

### Type SV

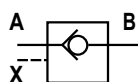

### Type SL

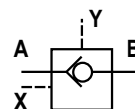

- 6 Area  $A_1$
- 7 Area  $A_2$
- 8 Area  $A_3$
- 9 Area  $A_4$

**Technical data** (for applications outside these parameters, please consult us!)**General**

Installation			Optional				
Ambient temperature range	°C		– 30 ... + 80 (NBR seals)				
	°C		– 20 ... + 80 (FKM seals)				
Nominal size			10	16	20	25	32
Weight	Subplate mounting	kg	1.8		4.7		7.8
	Threaded connections	kg	2.1	5.4	5.4	10	10

**Hydraulic**

Maximum operating pressure		bar	315				
Maximum flow			See characteristic curves, page 4				
Flow direction			Free-flow from A to B, from B to A when pilot operated				
Control pressure		bar	5 to 315				
Control volume	Port X	cm <sup>3</sup>	2.5	10.8	10.8	19.27	19.27
	Port Y (only type SL)	cm <sup>3</sup>	2.0	9.6	9.6	17.5	17.5
Control areas (areas according to sectional drawing, see page 2)	Area A <sub>1</sub>	cm <sup>2</sup>	1.33	3.46	3.46	5.72	5.72
	Area A <sub>2</sub>	cm <sup>2</sup>	0.33	0.7	0.7	1.33	1.33
	Area A <sub>3</sub>	cm <sup>2</sup>	3.8	10.17	10.17	16.61	16.61
	Area A <sub>4</sub>	cm <sup>2</sup>	0.79	1.13	1.13	1.54	1.54
Pressure fluid			Mineral oil (HL, HLP) to DIN 51 524 <sup>1)</sup> ; Fast bio-degradable pressure fluids to VDMA 24 568 (also see RE 90 221); HETG (rape seed oil) <sup>1)</sup> ; HEPG (polyglycols) <sup>2)</sup> ; HEES (synthetic ester) <sup>2)</sup> ; other pressure fluids on request				
Pressure fluid temperature range	°C		– 30 ... + 80 (NBR seals)				
	°C		– 20 ... + 80 (FKM seals)				
Viscosity range		mm <sup>2</sup> /s	2.8 ... 500				
Degree of contamination			Maximum permissible degree of contamination of the pressure fluid is to NAS 1638 class 9. We therefore recommend a filter with a minimum retention rate of $\beta_{10} \geq 75$ .				

<sup>1)</sup> Suitable for NBR **and** FKM seals

<sup>2)</sup> Only suitable for FKM seals

**Characteristic curves** (measured with HLP46,  $\vartheta_{oil} = 40 \text{ }^\circ\text{C} \pm 5 \text{ }^\circ\text{C}$ )

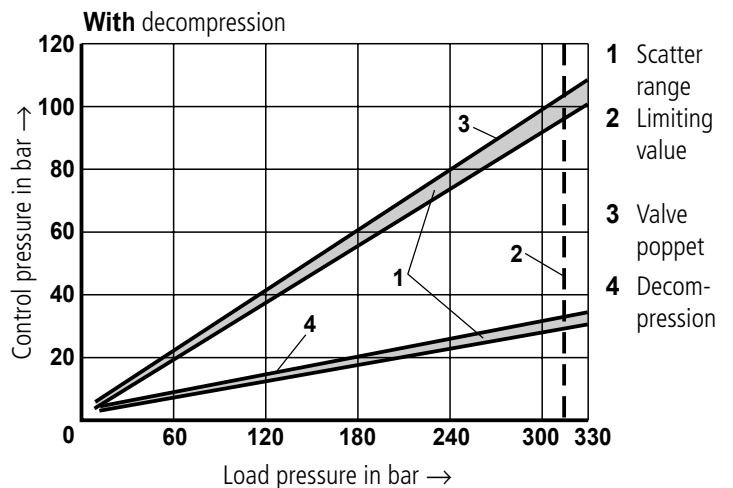
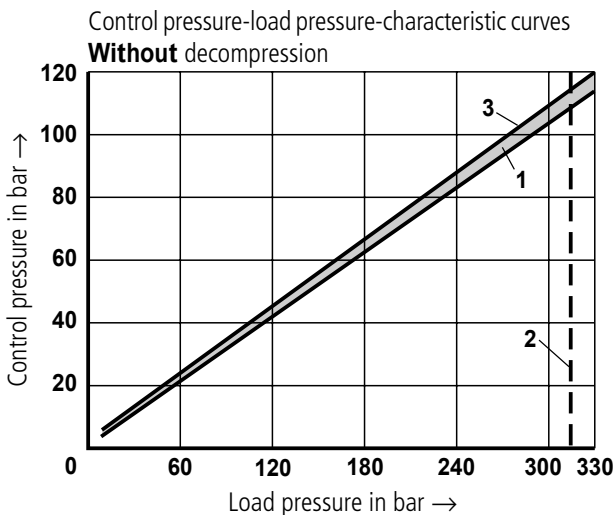
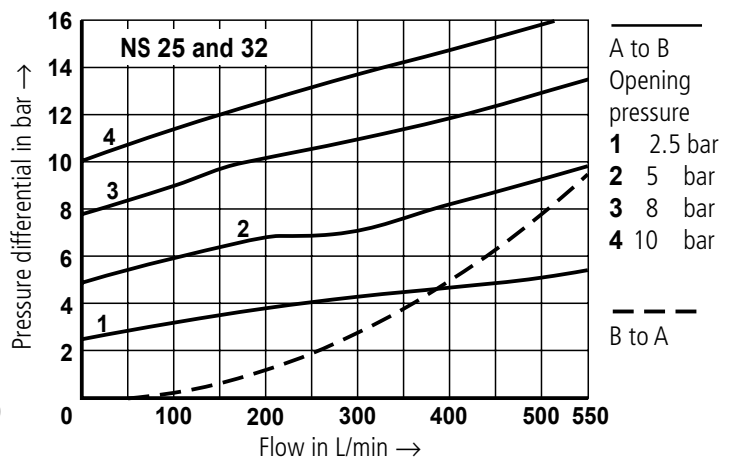
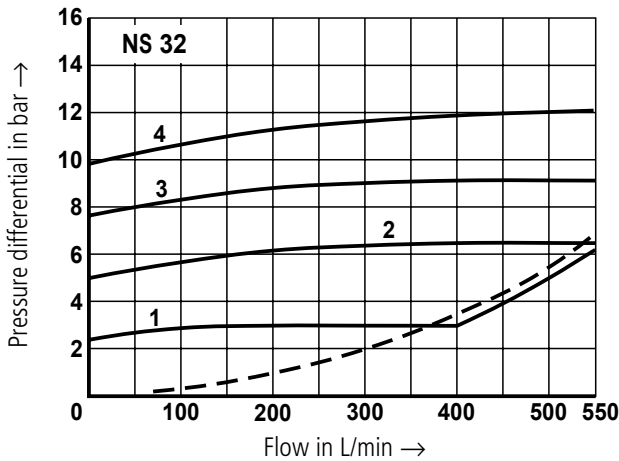
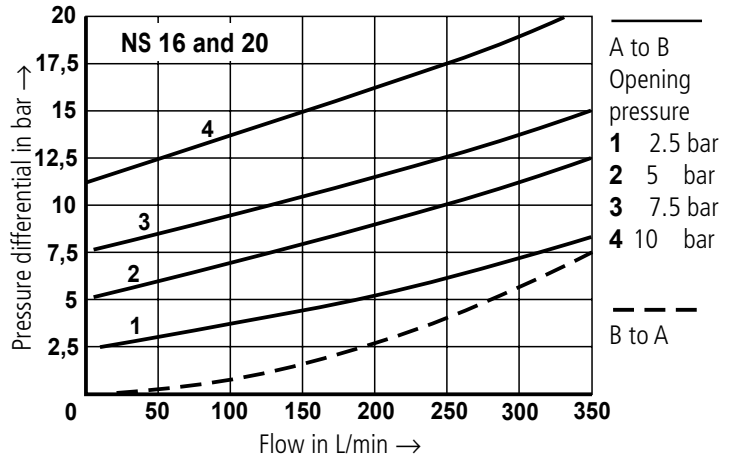
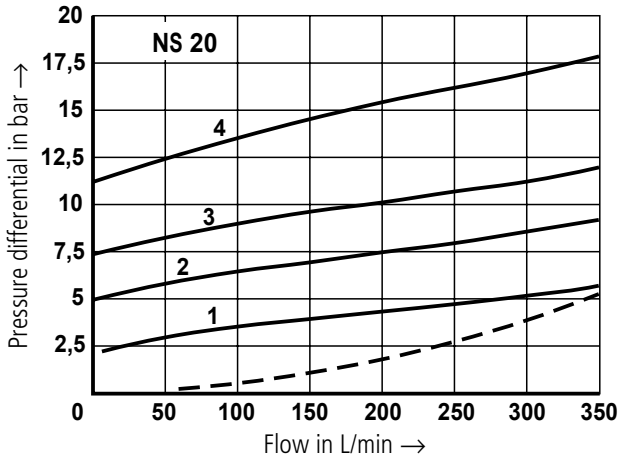
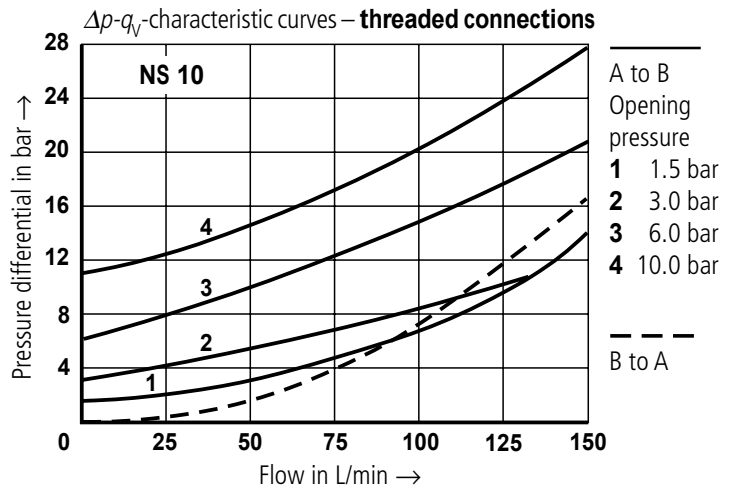
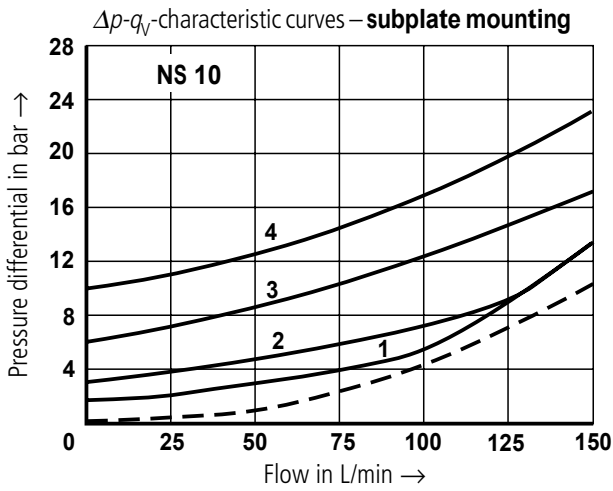

**Unit dimensions: subplate mounting** (dimensions in mm)

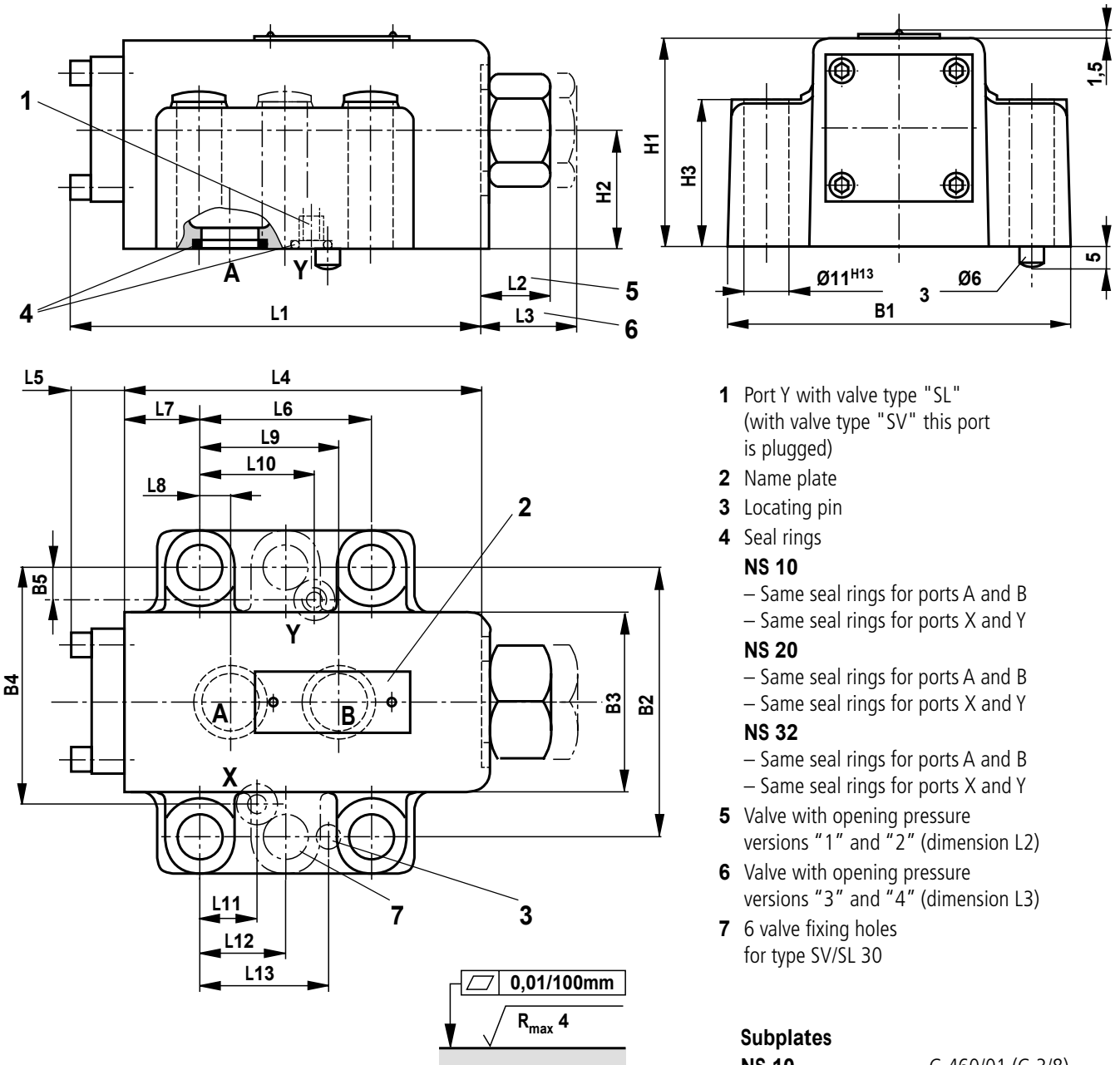

- 1 Port Y with valve type "SL" (with valve type "SV" this port is plugged)  
 2 Name plate  
 3 Locating pin  
 4 Seal rings  
**NS 10**  
 – Same seal rings for ports A and B  
 – Same seal rings for ports X and Y  
**NS 20**  
 – Same seal rings for ports A and B  
 – Same seal rings for ports X and Y  
**NS 32**  
 – Same seal rings for ports A and B  
 – Same seal rings for ports X and Y  
 5 Valve with opening pressure versions "1" and "2" (dimension L2)  
 6 Valve with opening pressure versions "3" and "4" (dimension L3)  
 7 6 valve fixing holes for type SV/SL 30

**Subplates**

- NS 10** G 460/01 (G 3/8)  
 G 461/01 (G 1/2)  
**NS 20** G 412/01 (G 3/4)  
 G 413/01 (G 1)  
**NS 32** G 414/01 (G 1 1/4)  
 G 415/01 (G 1 1/2)

**Valve fixing screws**

- NS 10**  
 4 off M10 x 50 DIN 912-10.9;  
 $M_A = 75 \text{ Nm}$   
**NS 20**  
 4 off M10 x 70 DIN 912-10.9;  
 $M_A = 75 \text{ Nm}$   
**NS 32**  
 6 off M10 x 85 DIN 912-10.9;  
 $M_A = 75 \text{ Nm}$

Subplates to catalogue sheet RE 45 062 and valve fixing screws must be ordered separately.

Type	NS	L1	L2	L3	L4	L5	L6	L7	L8	L9	L10
SV	10	100.8	15.5	15.5	87.8	13	42.9	18.5	7.2	35.8	–
	20	135	17.7	47.7	117	18	60.3	27.5	11.1	49.2	–
	32	156.1	36.1	46.1	134	22.1	84.2	39	16.7	67.5	–
SL	10	100.8	15.5	15.5	87.8	13	42.9	18.5	7.2	35.8	21.5
	20	135	17.7	47.7	117	18	60.3	27.5	11.1	49.2	39.5
	32	156.1	36.1	46.1	134	22.1	84.2	39	16.7	67.5	59.5

Type	NS	L11	L12	L13	B1	B2	B3	B4	B5	H1	H2	H3
SV	10	21.5	–	31.8	84	66.7	44	58.8	–	51	29	36
	20	20.6	–	44.5	100	79.4	61	73	–	70	37	55
	32	24.6	42.1	62.7	118	96.8	75	92.8	–	85	42.5	70
SL	10	21.5	–	31.8	84	66.7	44	58.8	7.9	51	29	36
	20	20.6	–	44.5	100	79.4	61	73	6.4	70	37	55
	32	24.6	42.1	62.7	118	96.8	75	92.8	3.8	85	42.5	70

**Unit dimensions: threaded connections** (dimensions in mm)

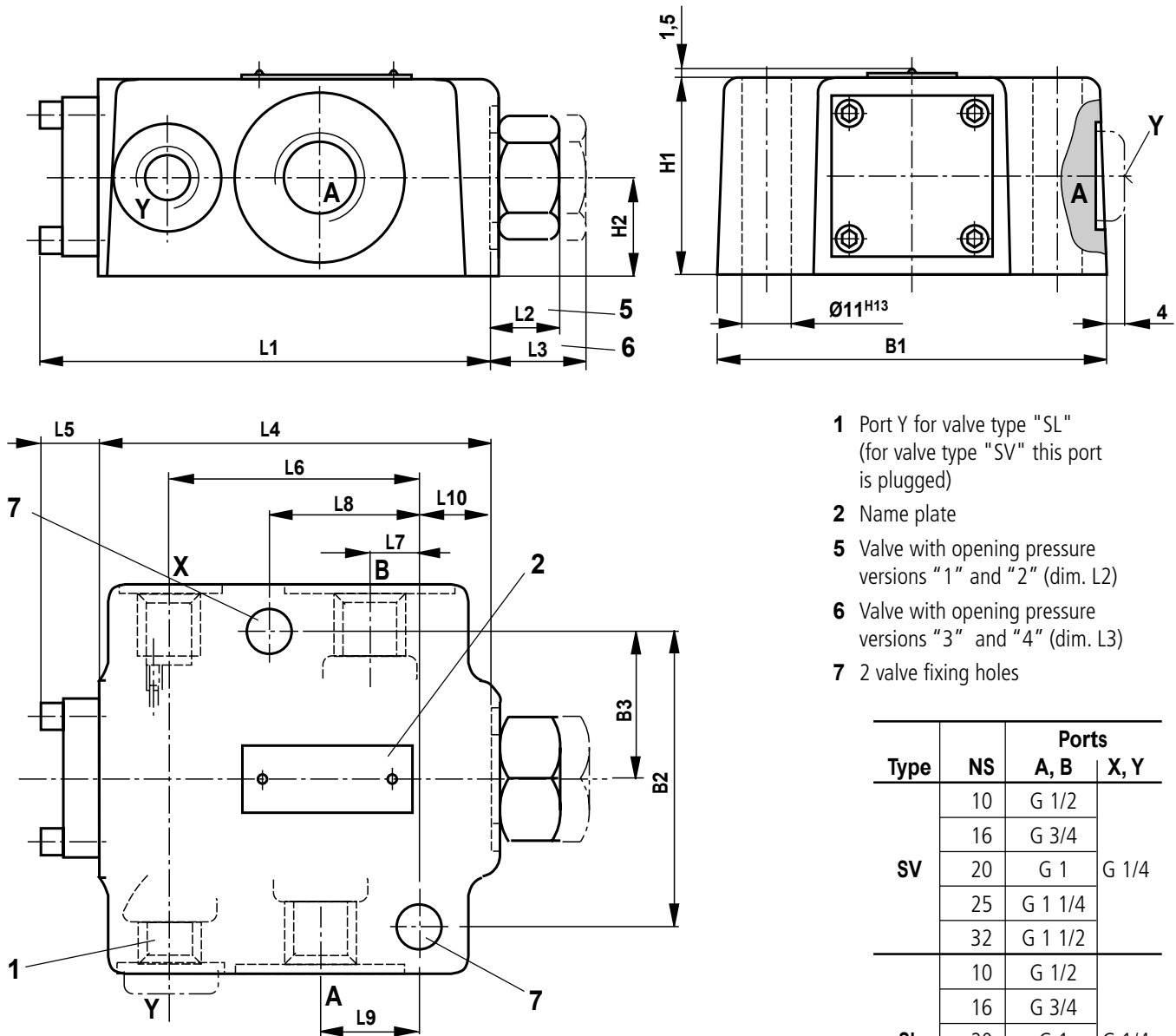

- 1 Port Y for valve type "SL" (for valve type "SV" this port is plugged)
- 2 Name plate
- 5 Valve with opening pressure versions "1" and "2" (dim. L2)
- 6 Valve with opening pressure versions "3" and "4" (dim. L3)
- 7 2 valve fixing holes

Type	NS	Ports	
		A, B	X, Y
SV	10	G 1/2	G 1/4
	16	G 3/4	
	20	G 1	
	25	G 1 1/4	
	32	G 1 1/2	
SL	10	G 1/2	G 1/4
	16	G 3/4	
	20	G 1	
	25	G 1 1/4	
	32	G 1 1/2	

Type	NS	L1	L2	L3	L4	L5	L6	L7	L8	L9	L10	B1	B2	B3	H1	H2
SV	10	100.8	15.5	15.5	87.8	13	56.5	10.5	33.5	22.5	17.3	87	66.7	33.4	44	22
	16; 20	133	17.7	47.7	115	18	74.5	17	50.5	36	27	105	79.4	39.7	68	34
	25; 32	156.1	35.7	45.7	134	22.1	101	24	84	49	18	130	96.8	48.4	85	42.5
SL	10	100.8	15.5	15.5	87.8	13	56.5	10.5	33.5	22.5	17.3	87	66.7	33.4	44	22
	16; 20	133	17.7	47.7	115	18	74.5	17	50.5	36	27	105	79.4	39.7	68	34
	25; 32	156.1	35.7	45.7	134	22.1	101	24	84	49	18	130	96.8	48.4	85	42.5